

SORTER STAPLER

1. OVERALL MACHINE INFORMATION

1.1 SPECIFICATIONS

Configuration: Console

Number of Bins: 20 + proof tray

Paper for Proof Tray: Size: Maximum: A3, 11" x 17"
 Minimum: A5, 5 1/2" x 8 1/2" (sideways)
 Weight: 52 g/m² ~ 160 g/m², 14 ~ 43 lb

Paper for Bins: Sort/Stack Mode:
 Size Maximum: A3, 11" x 17"
 Minimum: A5, 5 1/2" x 8 1/2" (sideways)
 Weight 52 g/m² ~ 160 g/m², 14 lb ~ 43 lb

Staple Mode:
 Size Maximum: A3, 11" x 17"
 Minimum: A4, 8 1/2" x 11"
 Weight 64 g/m² ~ 80 g/m², 17 lb ~ 21 lb

Stapler Capacity: From 2 to 50 sheets (80 g/m², 20 lb)

Bin Capacity:

	1 sided copies	2 sided copies
Sort mode	70 sheets	50 sheets
Stack mode	50 sheets	35 sheets

(80 g/m², 20 lb)

Proof Tray Capacity: 250 sheets (80 g/m², 20 lb)
 20 sheets (translucent paper)

Staple Position: a = b = 5 ± 2 mm

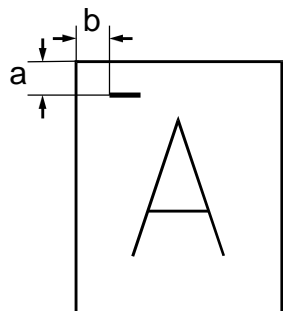

A591V500.wmf

Staple Time: Within 1.5 seconds/staple

Staple Replenishment: Cartridge exchange (5,000 pieces/cartridge)

Power Source: 1st sorter: 100 V (from copier)
 2nd sorter: 120 V (for U.S.A.)
 220/230/240 V (for Europe)

Power Consumption: Maximum: 0.2 kW

Dimensions: (1st sorter only) 580 x 828 x 1063 mm
 (22.8" x 32.6" x 41.8")
 (1st and 2nd sorter) 1120 x 828 x 1063 mm
 (44.1" x 32.6" x 41.8")

Weight: 1st sorter: 98 kg, 216 lb
 2nd sorter: 90 kg, 198 lb

1.2 MECHANICAL COMPONENT LAYOUT

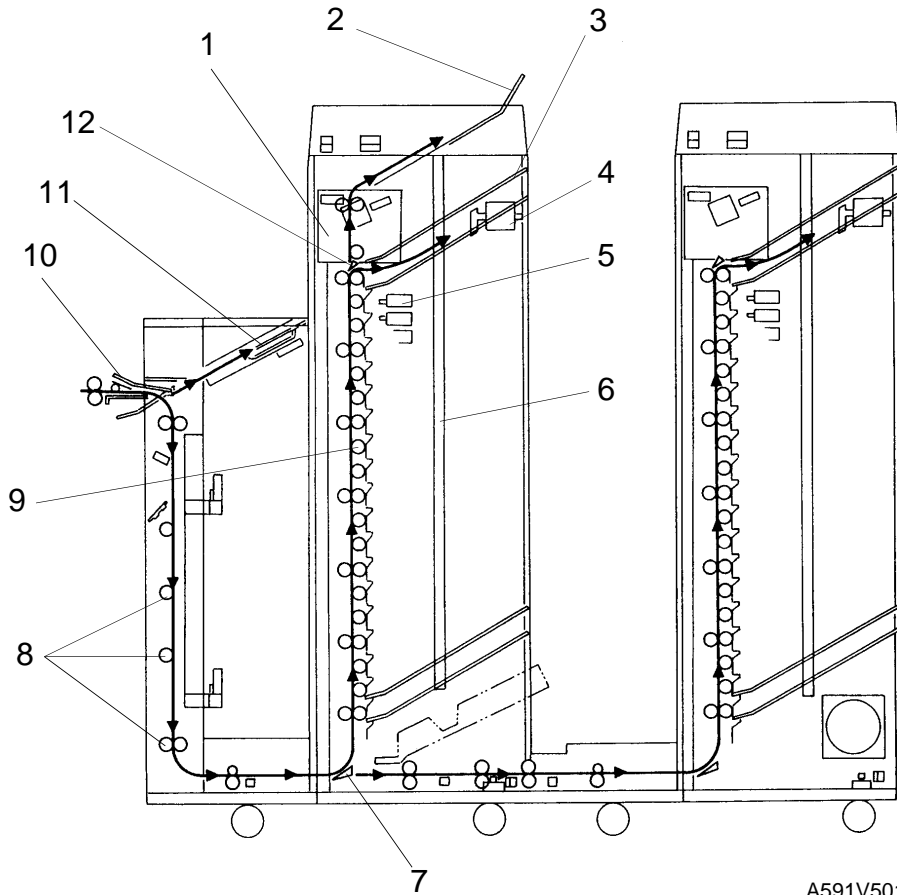

A591V501.img

- | | |
|------------------|-------------------------------|
| 1. Staple Unit | 7. Relay Gate |
| 2. Proof Tray | 8. Diagonal Transport Rollers |
| 3. Bins | 9. Distribution Rollers |
| 4. Jogger | 10. By-pass Tray Gate |
| 5. Bin Solenoids | 11. By-pass Exit Tray |
| 6. Side Bar | 12. Bin Gate |

1.3 DRIVE LAYOUT

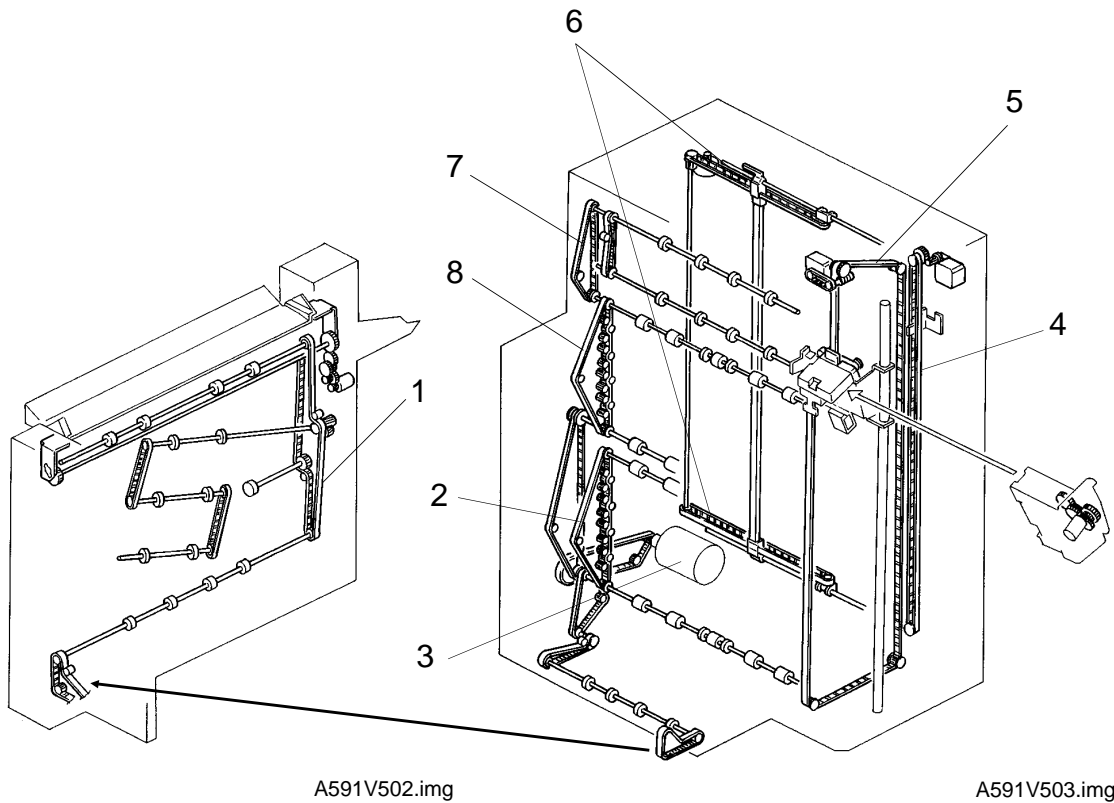

1. Diagonal Transport Drive Belt
2. Bin Drive Belt (11th to 20th)
3. Main Motor
4. Jogger Unit Drive Belt
5. Staple Unit Drive Belt
6. Side Bar Drive Belt
7. Proof Tray Exit Roller Drive Belt
8. Bin Drive Belt (1st to 10th)

1.4 ELECTRICAL COMPONENT DESCRIPTION

Symbol	Name	Function	Index No.
Motors			
M1	Main	Drives the diagonal transport unit, horizontal transport unit, and distribution unit through timing belts.	22
M2	Staple Unit Positioning	Drives the staple unit up or down to the appropriate bin. (dc stepper)	5
M3	Jogger Unit Positioning	Drives the jogger unit up or down to the appropriate bin. (dc stepper)	9
M4	Side bar	Drives the side bar side to side according to the paper size. (dc stepper)	1
M5	Grip	Drives the gripper forward into the bin to grip the copies and bring them to the stapling position. (dc brush)	12
M6	Staple	Feeds the staples and drives the stapler hammer. (dc brush)	15
M7	Jogger	Drives the jogger arm to align the copy. (dc stepper)	18
M8	By-pass Tray Gate	Drives the by-pass tray gate up or down to switch the paper delivery tray.	36
Switches			
SW1	Front Door	De-energize the main motor and cuts 24 V line when the front door is open.	8
SW2	Vertical Transport Door	De-energize the main motor when the vertical transport door is open.	6
SW3	Horizontal Transport Door	Informs the main board if the cover is open.	20
Circuit Boards			
PCB1	Main	Controls overall sorter stapler functions.	31
PCB2	DC Power Supply	Convert ac voltage to 5 V dc and 24 V dc to supply power to all dc components.	26
PCB3	Bin Solenoid Control 1	Interfaces between the bin solenoids 1 ~ 10 and the main board.	28
PCB4	Bin Solenoid Control 2	Interfaces between the bin solenoids 11 ~ 20 and the main board.	30
Solenoids			
SOL1~20	Bin	Opens and closes the bin gate to direct the copies into the appropriate bin.	27
SOL21	Grip	Opens and closes the bin gate to drive the grippers to grip copies on the bins.	14
SOL22	Pressure Release	Releases pressure of the brake roller when the paper is fed lengthwise.	38
SOL23	Relay Solenoid	Turn the relay gate to transport the copy to the 2nd sorter.	43

Symbol	Name	Function	Index No.
Sensors			
S1	Entrance	Detects paper jams at the entrance of the diagonal transport unit.	37
S2	Registration	Detects paper jams at the horizontal transport unit.	21
S3	Proof Tray Exit	Detects paper jams at the proof tray exit.	2
S4	Bin/Jam (LED)	Detects if paper is in the bin. Detects paper jams at the bin.	3
S5	Bin/Jam (Photo Tr)	Detects if paper is in the bin. Detects paper jams at the bin.	19
S6	Staple Unit H.P.	Detects if the staple unit is in the home position.	4
S7	Jogger Unit H.P.	Detects if the jogger unit is in the home position.	10
S8	Grip H.P.	Detects if the gripper is in the home position.	11
S9	Hammer H.P.	Detects if the staple hammer is in the home position.	13
S10	Jogger H.P.	Detects if the jogger arm is in the home position.	17
S11	Side Bar H.P.	Detects if the side bar is in the home position.	33
S12	Tray Gate H.P.	Detects if the by-pass tray gate is in the home position.	34
S13	Tray Gate Upper Position	Detects if the by-pass tray gate is in the upper position.	35
S14	Staple Unit Position	Detects the position of the staple unit.	32
S15	Paper	Detect if copies are under the hammer.	7
S16	Staple End	Detects if the staple is present.	16
S17	Diagonal Transport Door Open	Detects if the diagonal transport door is open.	39
S18	Timing	Supplies timing pulses to the main board.	29
S19	Relay Unit Cover Open	Detects if the relay unit cover is open.	41
S20	Relay Sensor	Detects paper jam at the relay unit.	42
Capacitor			
C1	Main Motor	Protects the PCB's from induced current.	23
Noise Filter			
NF1	Noise Filter	Removes electrical noise generated by the copier and the sorter stapler.	25
Relay			
RA1	Main	Controls main power.	24
Transformer			
TF1	2nd Sorter	Steps down the line voltage to 100 Vac.	42

1.5 BASIC OPERATION

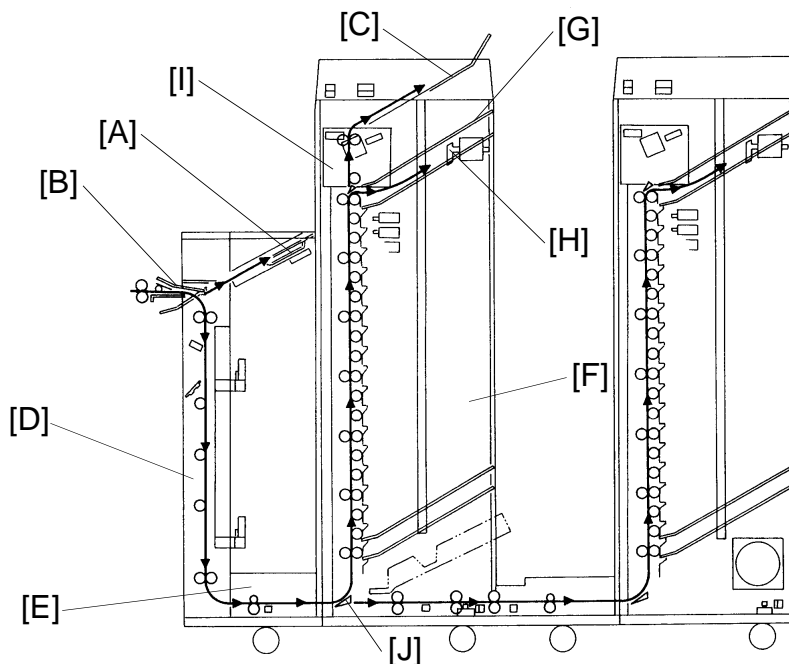

A591V501.img

Copies exiting the copier enter the sorter or the by-pass tray [A] depending on the by-pass tray gate [B] position. In normal operation, copies are sent to the sorter, if paper jams occur in the sorter, the remaining papers in the copier are fed to the by-pass tray.

If sort/stack mode is not selected, copies are delivered to the proof tray [C] through the diagonal transport unit [D], the horizontal transport unit [E], and the distribution unit [F].

When sort/stack mode is selected, copies are delivered to the bins [G] in order.

The copies in the bins are arranged by the jogger arm [H].

If staple mode is selected, when the last page of the original is delivered to the 1st bin, the staple unit [I] starts stapling the copies in each bin.

The 1st sorter has capacity to hold 20 sorted copies.

If the 2nd sorter is installed next to the 1st sorter, an additional 20 sorted copies can be sorted.

After the 20th copy is fed to the distribution unit of the 1st sorter, the relay gate [J] moves to the upper position and the 21st copy is transported to the 2nd sorter. After the final copy of the designated number has passed under the relay gate, the relay gate moves down to transport copies to the bins of the 1st sorter again.

2. SECTIONAL DESCRIPTION

2.1 PAPER DELIVERY SWITCHING

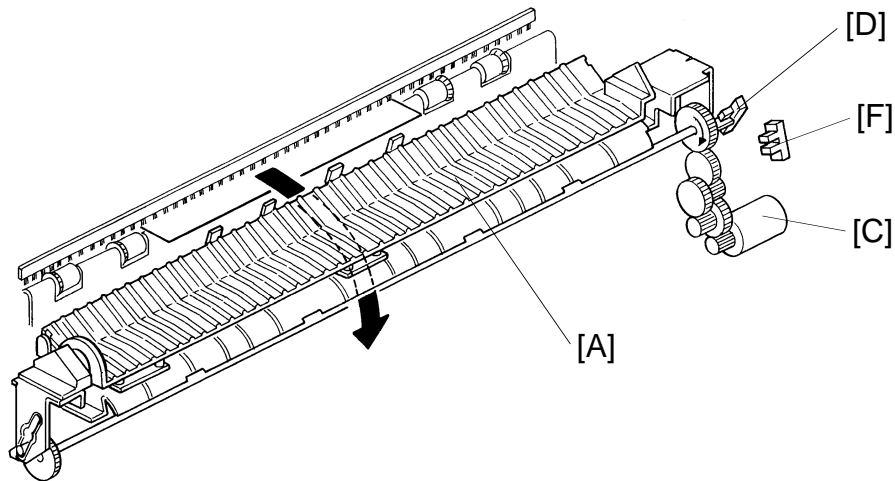

A591D500.img

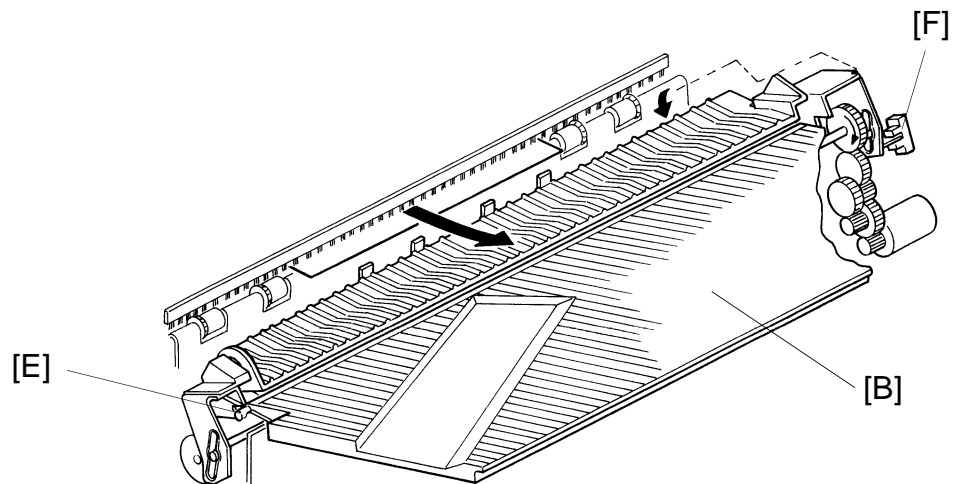

A591D501.img

Depending on the by-pass tray gate [A] position, paper fed from the copier enters either the sorter or the by-pass tray [B].

The by-pass tray gate is driven by the by-pass tray gate motor [C]. Under normal operating conditions, the by-pass tray gate is in the home position (H.P. sensor [D] is actuated) to deliver copies to the sorter. If a sorter paper jam occurs, the gate rotates on its shaft [E] until the upper tray gate position sensor [F] is actuated and stops.

2.2 DIAGONAL TRANSPORT

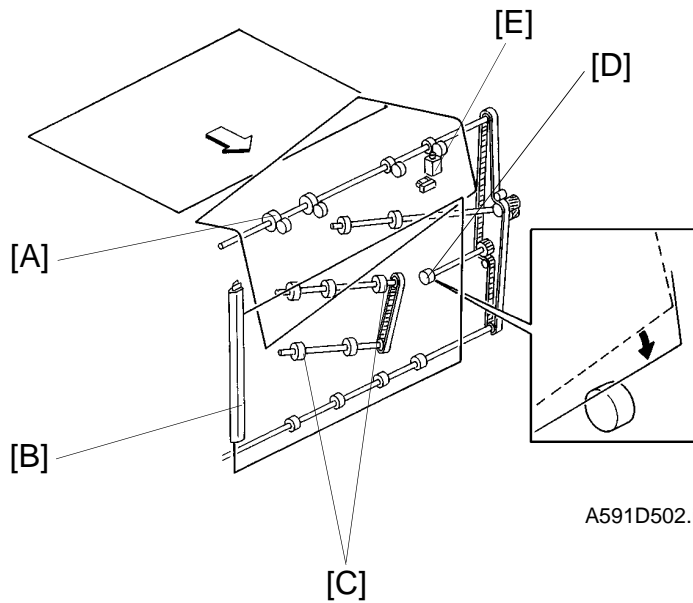

A591D502.img

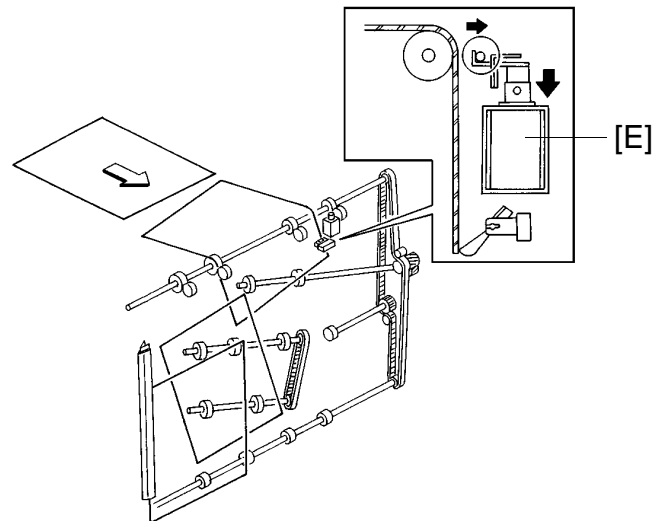

A591D503.img

Paper entering the diagonal transport unit is transported down to the horizontal transport unit. The front side of the paper advances more than the back side due to the front transport roller [A] being larger than the back rollers. This causes the paper to skew as it enters the diagonal transport unit. This skew prevents the diagonal transport guide [B] from catching the edge of the copies.

The paper is then moved to the front by the diagonal transport rollers [C]. Where it is aligned as it is guided by the diagonal transport guide [B].

The brake roller [D] prevents the rear side of the paper from falling forward.

If the paper is traveling lengthwise, the pressure release solenoid [E] turns on to prevent over skewing.

2.3 SORTING

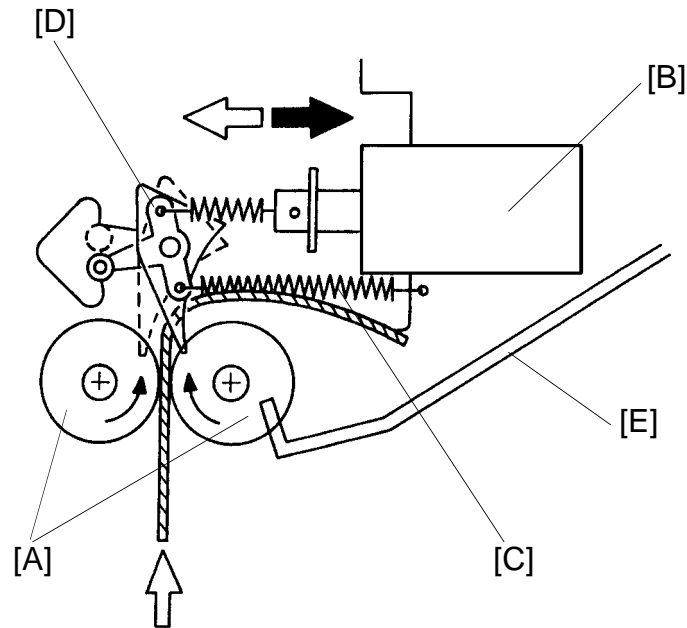

A591D504.img

The distribution section has the distribution rollers [A], 20 bin gates, and 20 bin solenoids.

When a bin gate solenoid [B] is off, the return spring [C] holds the bin gate [D] out of the paper path, allowing the copies to pass to the upper bin.

The appropriate bin gate solenoid turns on and opens the bin gate. The other solenoids are off. The copies go to the bin [E] through the gate.

2.4 PAPER JOGGING

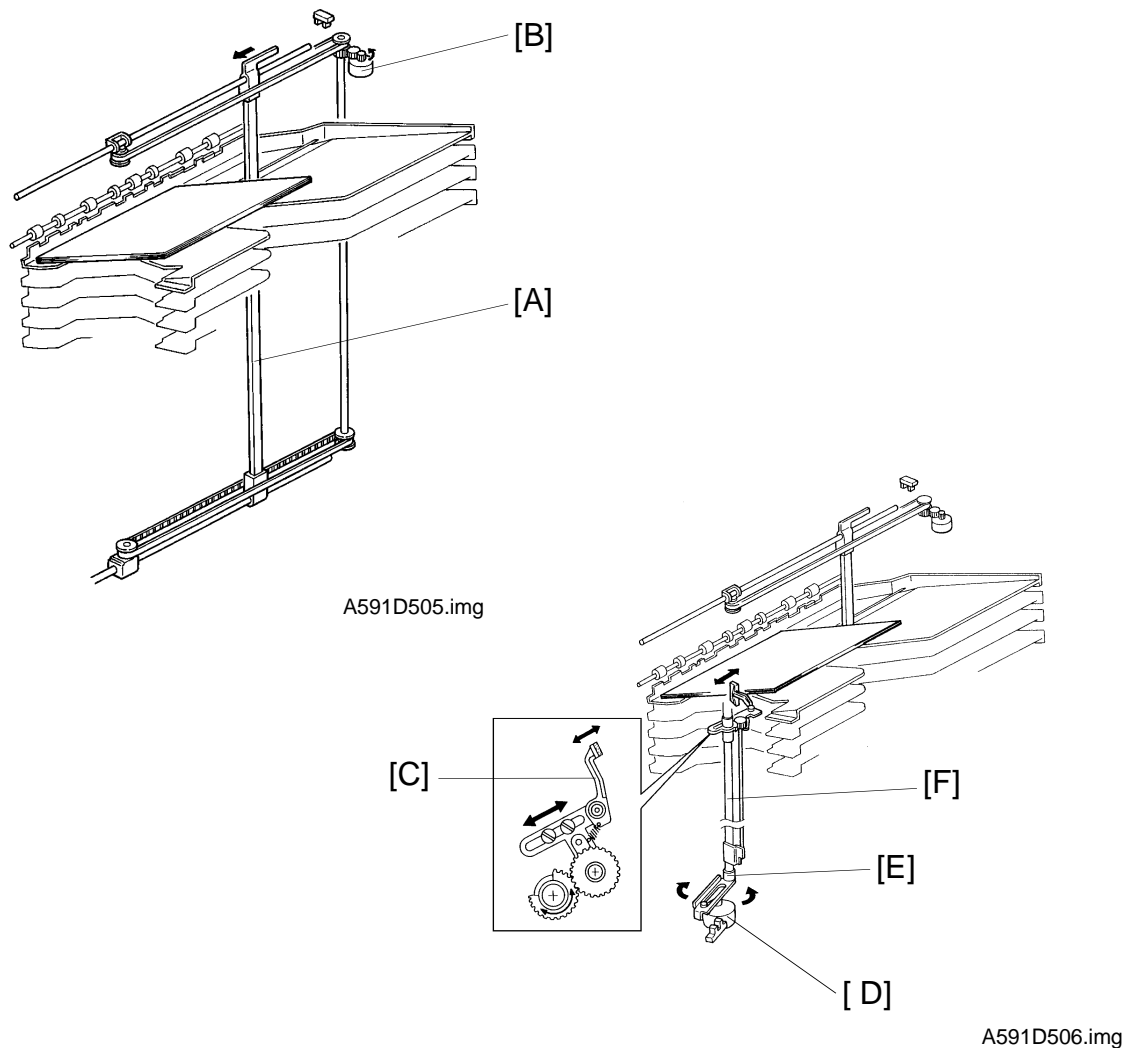

Ordinarily, the side bar [A] is in the home position. It moves to within 10 mm of the rear of the selected paper size. The side bar is driven by the side bar motor [B] through the gears and a timing belt.

The jogger arm [C] home position is 10 mm in front of the paper.

After the paper passes the jam sensor, the jogger arm moves twice due to the forward and reverse rotation of the jogger motor [D]. Jogger arm movement is controlled through the link [E] and jogger bar [F].

The reverse rotation of the jogger motor prevents motor lock caused by an overly stiff paper stack. Even if the overly stiff paper interferes with the jogger arm movement, the arm returns to its home position via the reverse rotation of the jogger motor.

2.5 STAPLING

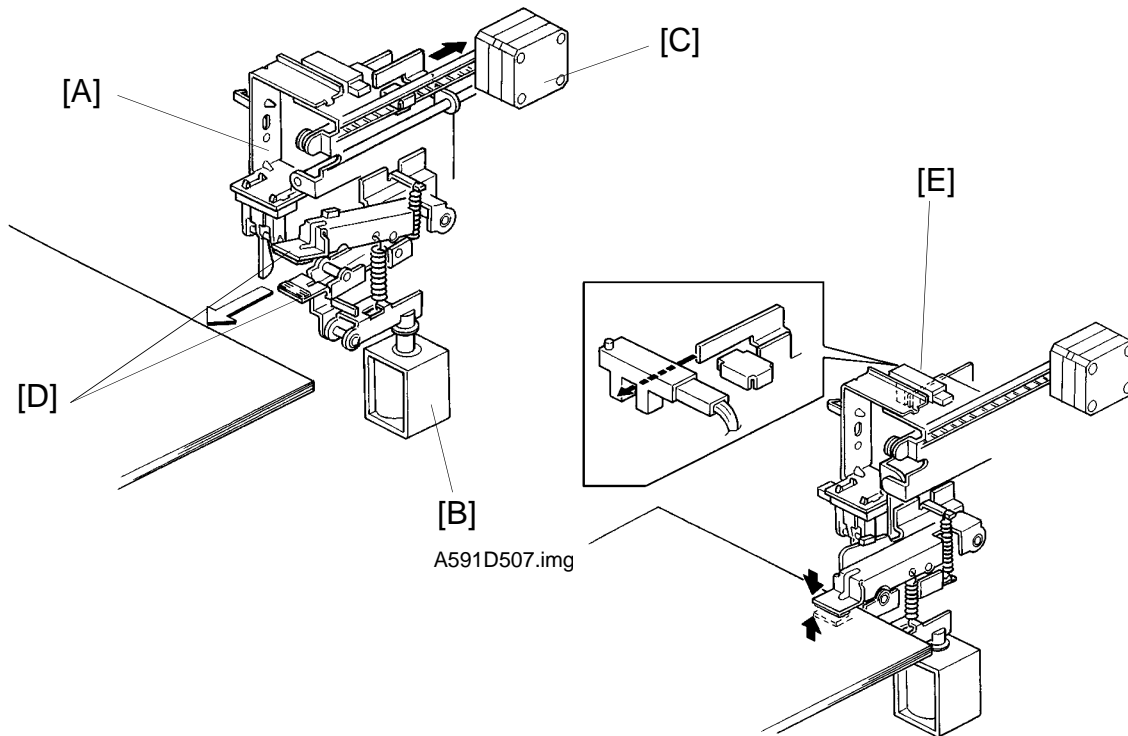

2.5.1 Gripper

A591D508.img

The grip unit [A] grips and moves the jogged paper to the staple position and returns the stapled paper to the bin.

The grip solenoid [B] and grip motor [C] are built into the grip unit. The motor moves the grippers [D] back and forth, and the solenoid [B] controls paper clamping.

When the grippers reach the paper in the bin, the grip solenoid turns on and the grippers grasp the paper.

The lower gripper arm has a shorter stroke to prevent it from disturbing the jogged paper in the bin.

Paper gripped by the grippers is moved by the grip motor into stapling position.

Resetting the main PCB DIP SW101-1 to 101-4 adjusts the stapling position (0.5 mm increments).

The stapled paper (held by the gripper arms throughout stapling) is returned to its original position. The grip solenoid turns off to release the stapled paper, and the gripper arms return to their original position.

The grip H.P. sensor [E] confirms that the grip unit has returned to its home position.

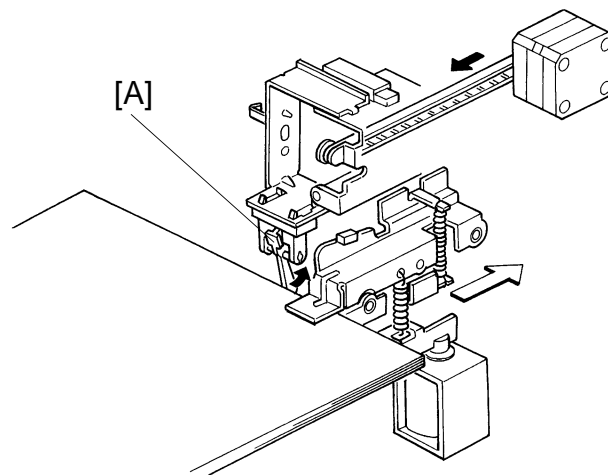

A591D509.img

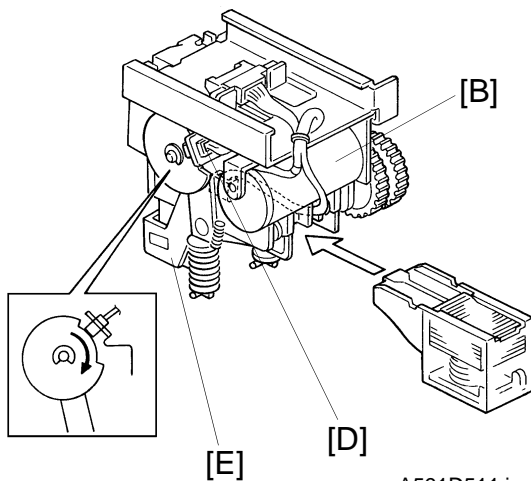

A591D511.img

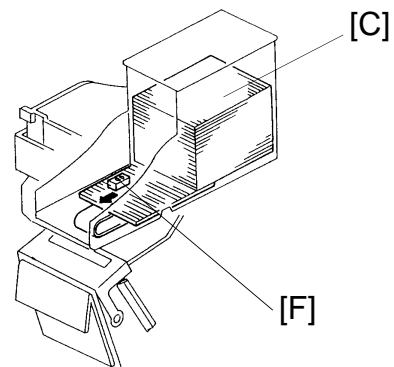

A591D510.img

2.5.2 Stapler

The paper sensor [A] prevents stapler operation when there is no paper in position. Also, it detects staple error if the paper sensor remains actuated when the stapler finishes its operation.

The staple motor [B] drives the stapling mechanism and transporting of the staples from the cartridge [C].

The hammer H.P. sensor [D] checks if the staple hammer [E] is in the home position.

The staple end sensor [F] checks if staples are present.

2.6 JOGGER UNIT POSITIONING

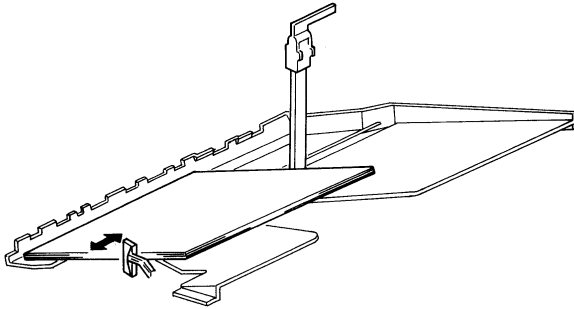

A591D512.img

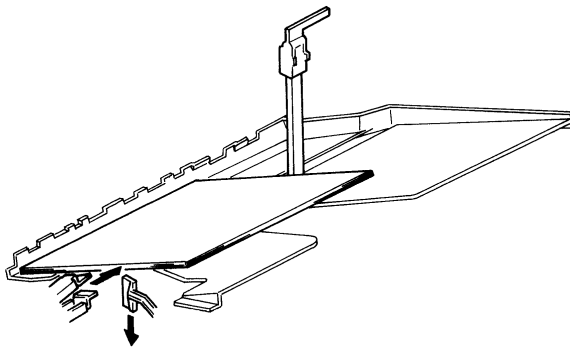

A591D513.img

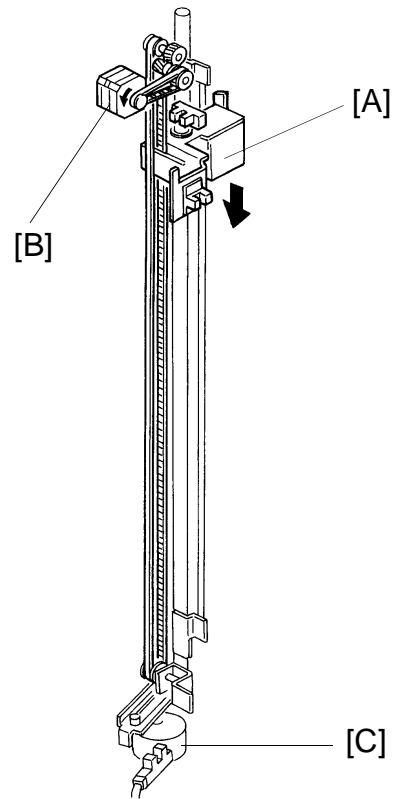

A591D514.img

The jogger unit [A] vertical position is controlled by the stepper motor [B]. Depending on the rotation of the stepper motor [C], the jogger unit moves to the appropriate bin.

When the main switch is turned on, the jogger unit will stop in its home position. During sorter operation, the motor starts rotating when jogger operation at any bin is complete. This lowers the jogger unit until it reaches to the next bin and then the motor stops.

When jogger operation for a designated number of copies is complete, the motor rotates to raise the jogger unit back to its home position.

2.7 STAPLE UNIT POSITIONING

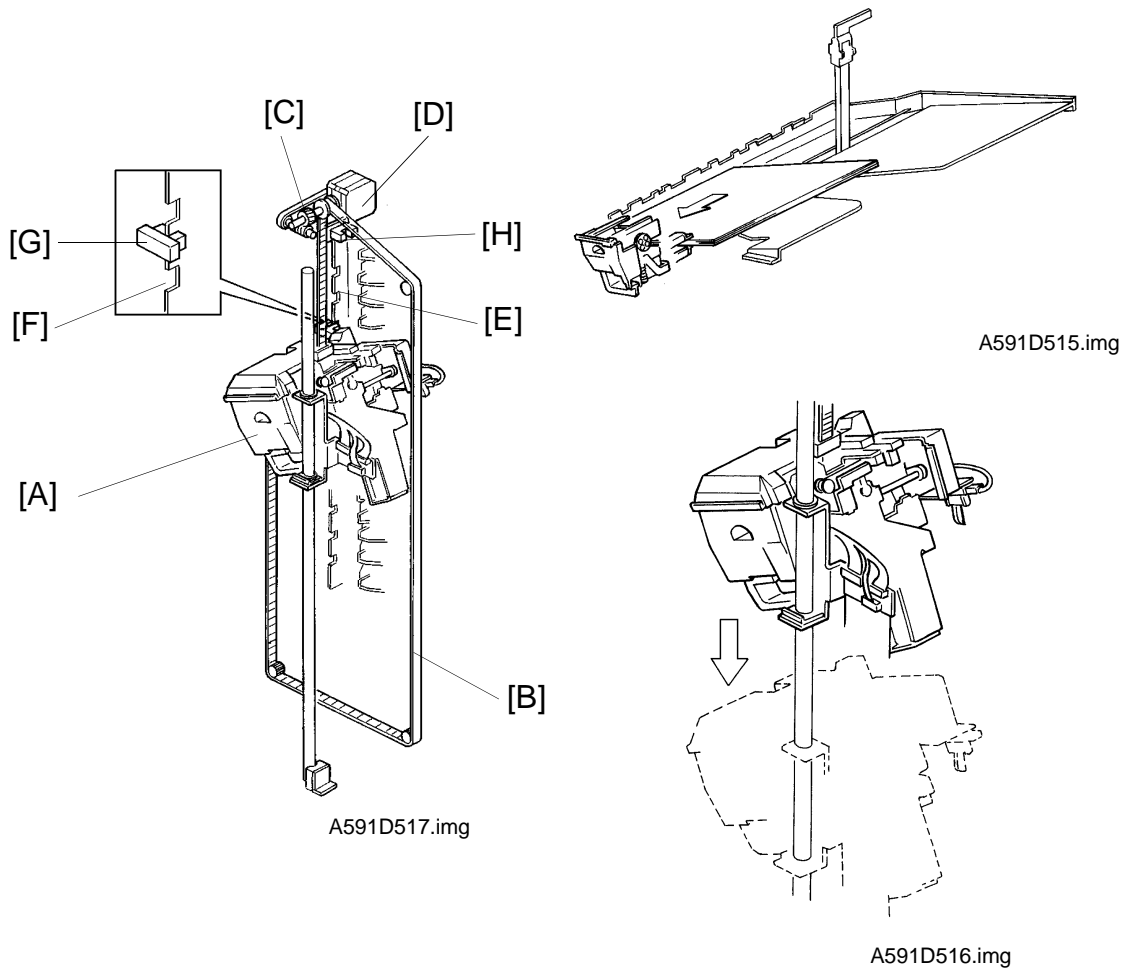

The staple unit [A] is hanging on the timing belt [B]. Due to the weight of this staple unit, accurate positioning is ensured by using worm gear [C] which transmits the staple positioning motor [D] rotation to the timing belt.

The bracket [E] guiding the staple unit has notches [F] which the staple unit position sensor [G] senses.

Initially, the staple unit is beside the top bin. When stapling at the first bin is completed, the staple unit positioning motor [D] energizes to move the staple unit to the next bin where stapling is repeated.

When stapling at the last bin is completed, the motor [D] rotates to raise the staple unit back to its home position. The staple positioning motor stops when the staple unit home position sensor [H] is actuated.

Raising the staple unit requires more torque than lowering it. Thus the motor speed when raising the staple unit will be approximately half of the lowering speed.

2.8 1ST AND 2ND SORTER CONNECTION

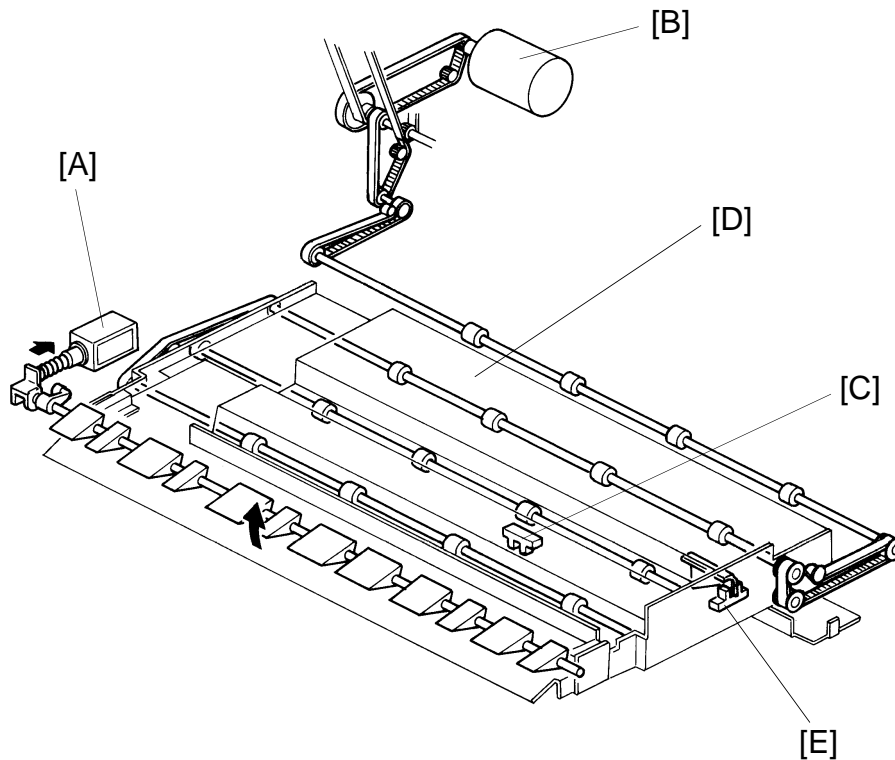

A591D518.img

When the 2nd sorter is connected, paper must be relayed from the 1st sorter to the 2nd sorter. A relay solenoid [A] has been added to the 1st sorter for this purpose.

A relay unit is also added to the 1st sorter to transport paper to the 2nd sorter.

The relay unit is driven by the 2nd sorter main motor [B].

The relay sensor [C] detects paper jams at the relay unit.

The relay unit cover [D] is provided to enable removal of misfed papers.

The interrupter [E] detects if the cover [D] is open.

2.9 DOOR SWITCHES

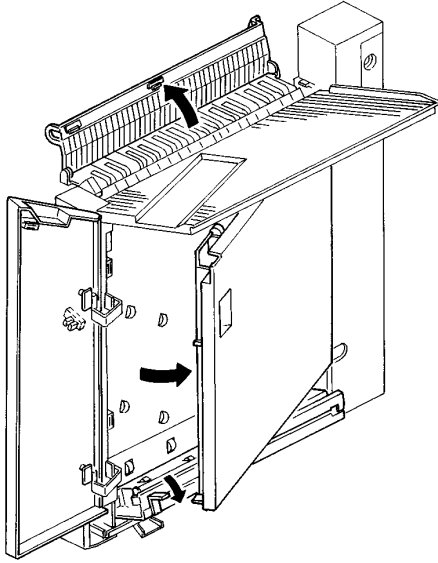

A591D519.img

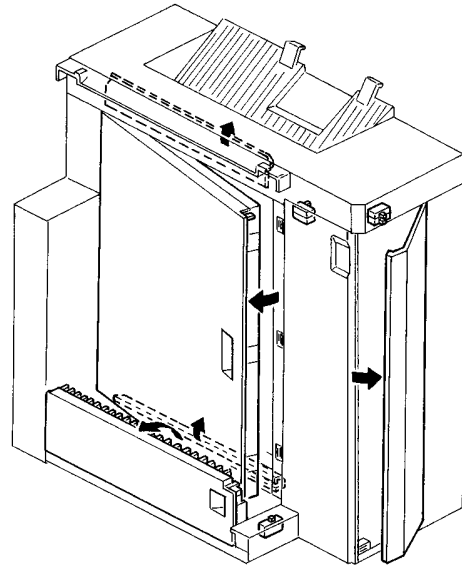

A591D520.img

Doors and guide plates are provided to enable removal of misfed papers.

Each door has a safety switch to detect opening and closing. These switches also perform the jam reset function.

2.10 JAM DETECTION

2.10.1 Jam Detection Condition

The jam detection timing is determined by pulses from the timing sensor. The diagram below illustrates the timing interval in which each sensor detects paper jams in operation.

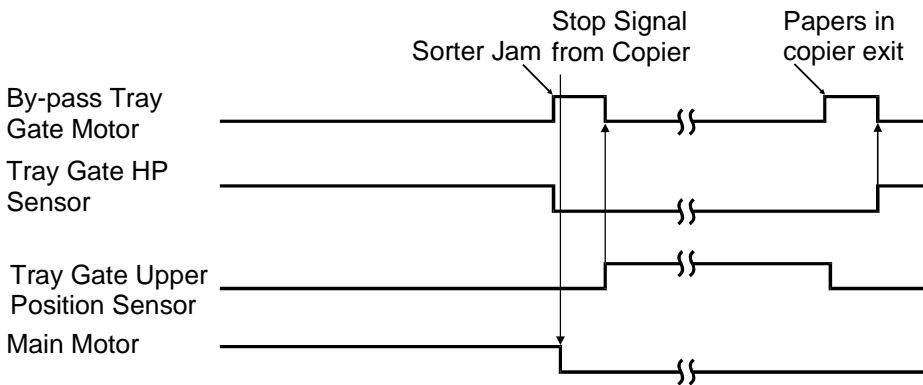
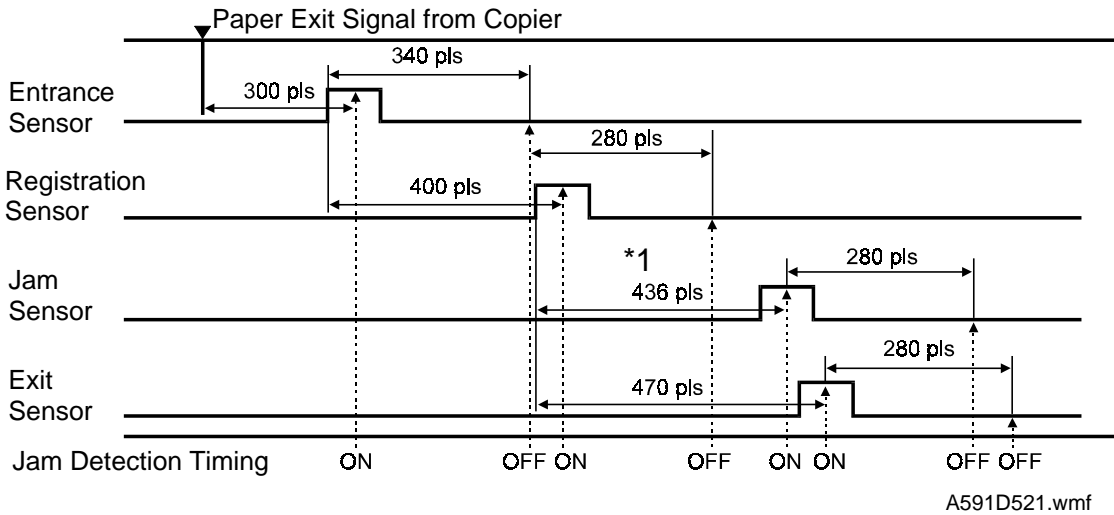

*1. Jam detection timing depends on the bin position

Bin No.	Pulses	Bin No.	Pulses	Bin No.	Pulses
proof	470	7	354	14	260
1	436	8	342	15	248
2	422	9	328	16	234
3	408	10	314	17	220
4	394	11	302	18	208
5	382	12	288	19	194
6	368	13	274	20	180

Staple failure is detected if the paper sensor is not de-energized after the machine finishes returning the stapled paper to the bin.

2.10.2 Machine Operation in Jam Conditions

- a. When a paper jam occurs in the copier, the sorter stapler stops after delivering papers in the sorter to the appropriate bins.
- b. When a paper jam occurs in the sorter stapler, the by-pass tray gate motor energizes and papers in the copier are delivered to the by-pass tray.
- c. When a staple failure is detected, the machine stops staple operation.

2.10.3 Jam Reset

- a. If a paper jam occurs at the diagonal transport unit, the jam condition is reset when the diagonal transport door is closed after removing the misfed paper.
- b. If a paper jam occurs in the sorter, the jam condition is reset when the vertical transport door or the horizontal transport door is closed after removing the misfed paper.
- c. If a staple failure occurs, the jam condition is reset when the sorter front door is closed after removing the unstapled paper.

2.10.4 Jam Recovery

Copies on the bin are counted by the jam sensor.

When the start key is pressed after misfed paper is removed, the machine delivers the copies from the continuance bin.

3. INSTALLATION PROCEDURE

3.1 1ST SORTER STAPLER

3.1.1 Accessories

1. Tray Extension.....	1
2. Original Guard	1
3. Upper Stay.....	1
4. Lower Stay.....	1
5. Harness Cover.....	1
6. Front Door.....	1
7. Lower By-pass Tray.....	1
8. Staple Cartridge.....	1
9. Leveling Shoe.....	2
10. M4 x 6 Screw	9
11. M4 x 8 Screw with Star Washer	2
12. Spacer	2
13. A2 Guide Plate (European version only).....	1

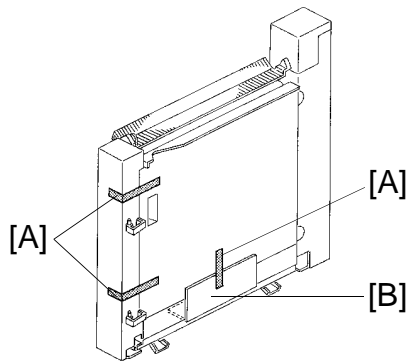

A591I500.img

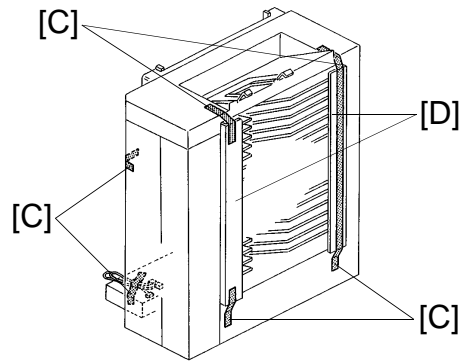

A591I501.img

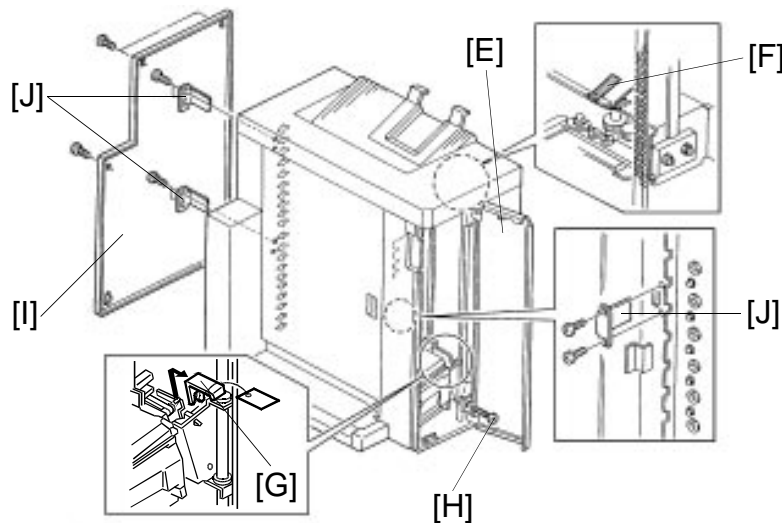

A591I502.wmf

CAUTION:

Unplug the copier power cord before starting the following procedure.

1. Remove the strips of filament tape [A] and remove the cushion [B] protecting the vertical transport door.
2. Remove the strips of filament tape [C] and remove the cushions [D] protecting the bins.
3. Open the front door [E] and remove the strips of filament tape [F] fixing the jogger unit.
4. Remove the shipping retainer [G] fixing the grip unit.
5. Remove the screw [H] fixing the staple unit.
6. Remove the rear cover [I] (6 screws).
7. Remove the three brackets [J] supporting the vertical transport cover (2 screws each).
8. Reinstall the rear cover.

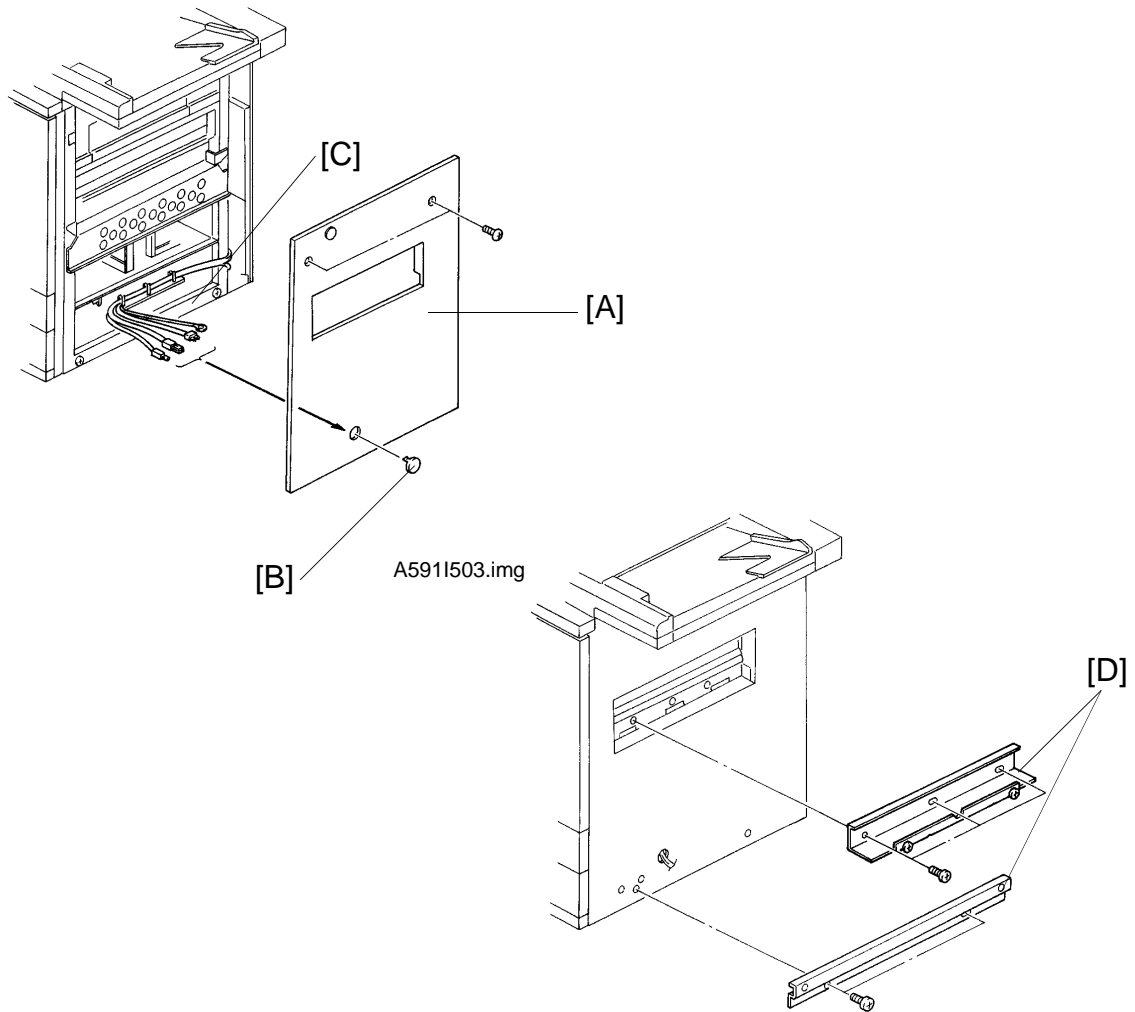

9. Remove the right cover [A] of the copier (2 screws) and the plastic cap [B]. Reinstall the right cover passing the interface harness [C] (3 connectors and 1 ground wire) through the hole of the lower right cover.
10. Fix the upper and lower stays [D] (5 screws) to enable fixing of the diagonal transport unit.

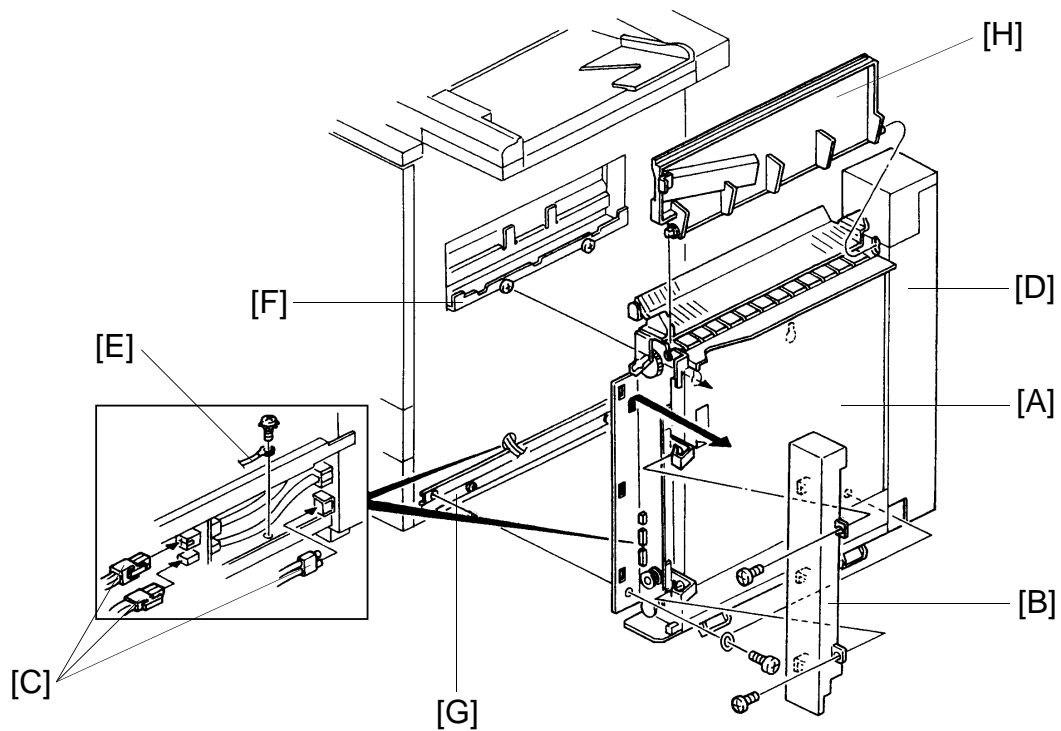

A5911505.img

11. Open the diagonal transport door [A] and remove the front cover [B] (2 screws) of the diagonal transport unit.
12. Set the connectors of the interface harness [C] from the copier to the diagonal transport unit [D].
13. Fix the ground line [E] to the diagonal transport unit (M4 x 8 screw with a star washer).
14. Hook the diagonal transport unit on the upper stay [F]. Then fix the unit to the lower stay [G] (2 screws and 2 spacers).
15. Install the lower by-pass tray [H].

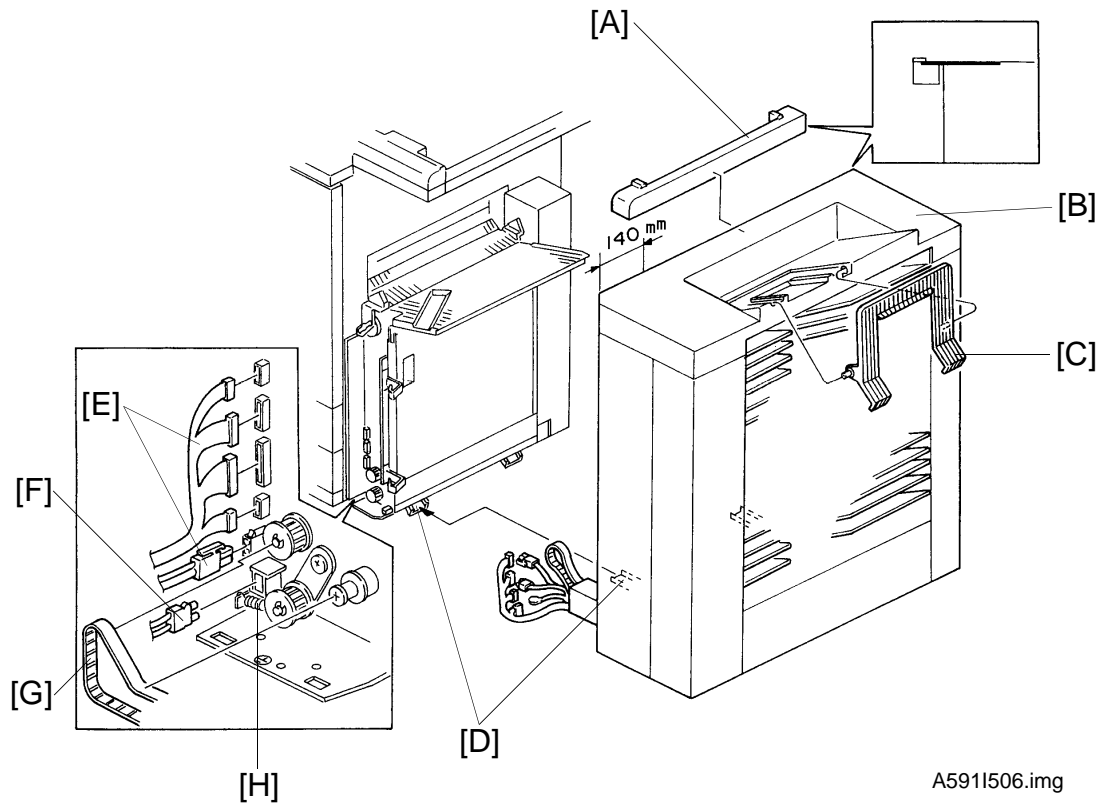

A591I506.img

16. Stick the original guard [A] onto the upper cover [B] of the 1st sorter.
NOTE: Stick it 140 mm from the end of the cover.
17. Install the tray extension [C].
18. Join the 1st sorter to the diagonal transport unit, pressing the 1st sorter until the two latches [D] lock together.
19. Connect the harness connectors [E] and the optical fiber cable [F].
20. Set the timing belt [G] and hook the tension spring [H].

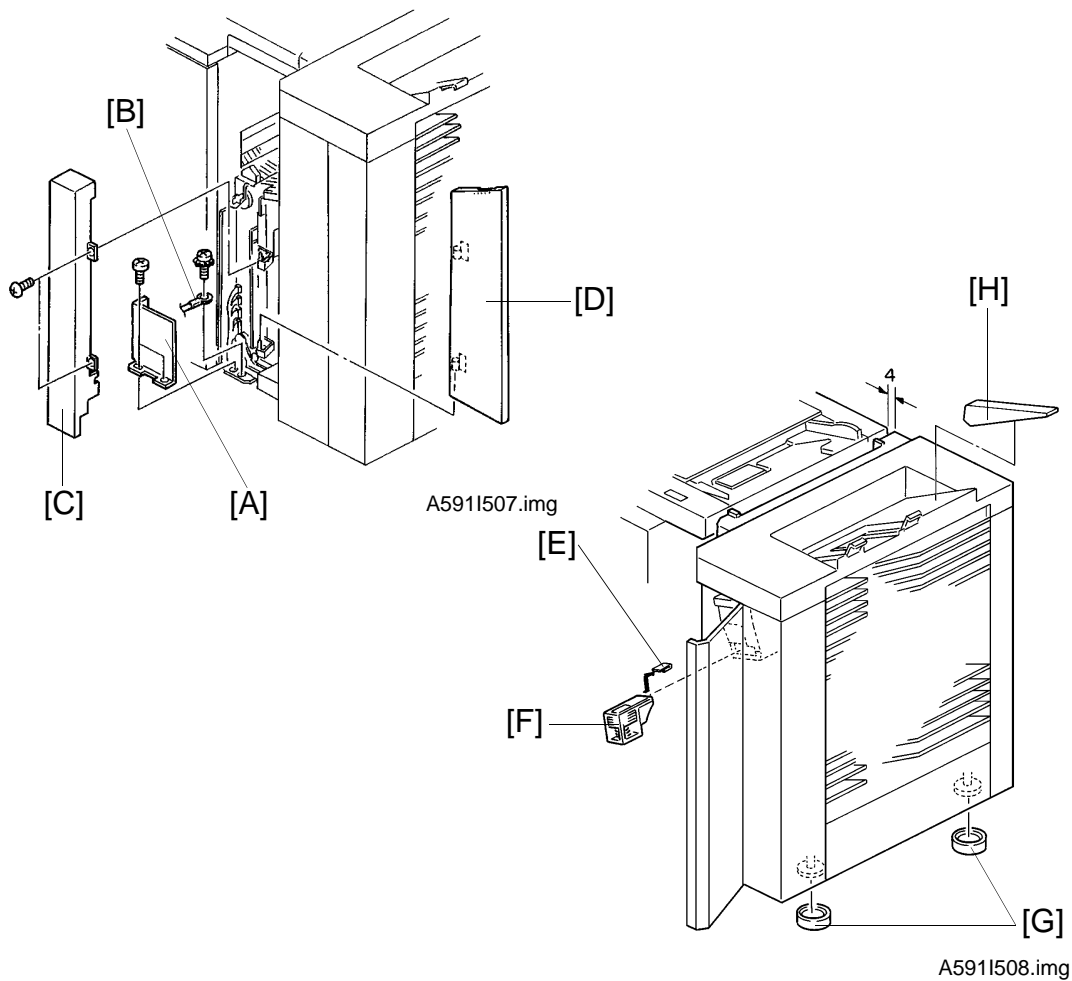

21. Install the harness cover [A] (2 M4 x 6 screws).
22. Fix the ground wire [B] onto the diagonal transport unit (M4 x 8 with star washer).
23. Install the front cover [C] of the diagonal transport unit (2 screws) and set the front door [D].
24. Open the front door of the sorter, remove the staple cover [E], and set the staple cartridge [F].
25. Put the two leveling shoes [G] under the feet. Adjust the sorter height by securing down feet so that the sorter is parallel to the copier.
26. Install the A2 guide plate [H] (European version only).
27. Turn on the main switch of the copier and test the operation of the sorter stapler.

NOTE: The stapler will not staple for the first 10 or so copies until the first staple from the cartridge reaches the proper position for stapling.

3.2 2ND SORTER STAPLER

3.2.1 Accessories

1. Relay Unit	1
2. Optical Fiber Cable	1
3. Tray Extension.....	1
4. Interface Board	1
5. Joint Bracket.....	1
6. Harness Cover Bracket	1
7. Motor Cover	1
8. Bin Bottom Bracket.....	1
9. Relay Gate Solenoid.....	1
10. Staple Cartridge.....	1
11. Leveling Shoe	2
12. Bushing	1
13. Relay Connector	1
14. Decal.....	1
15. M4 x 6 Philips Pan Head Screw	2
16. M4 x 6 Truss Head Screw	1
17. M4 x 6 Screw with Washer	2
18. M4 x 8 Screw with Star Washer	1
19. M4 x 6 Screw with Spring Washer	3
20. M4 x 8 Double Washer Screw	1
21. Flat Head Screw	1

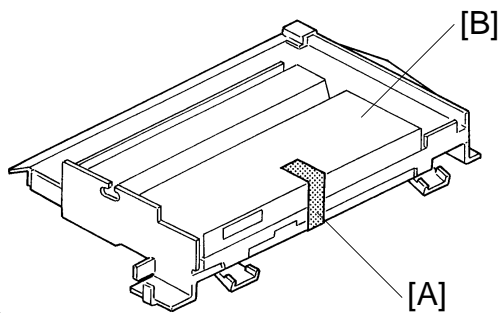

A5911509.img

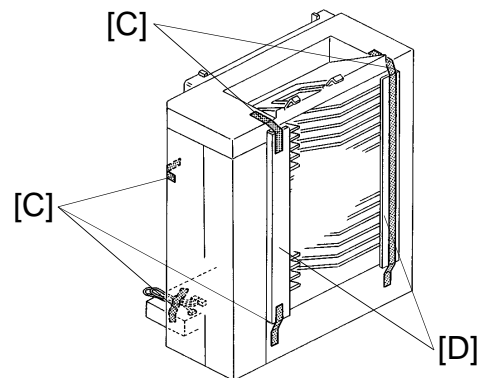

A5911501.img

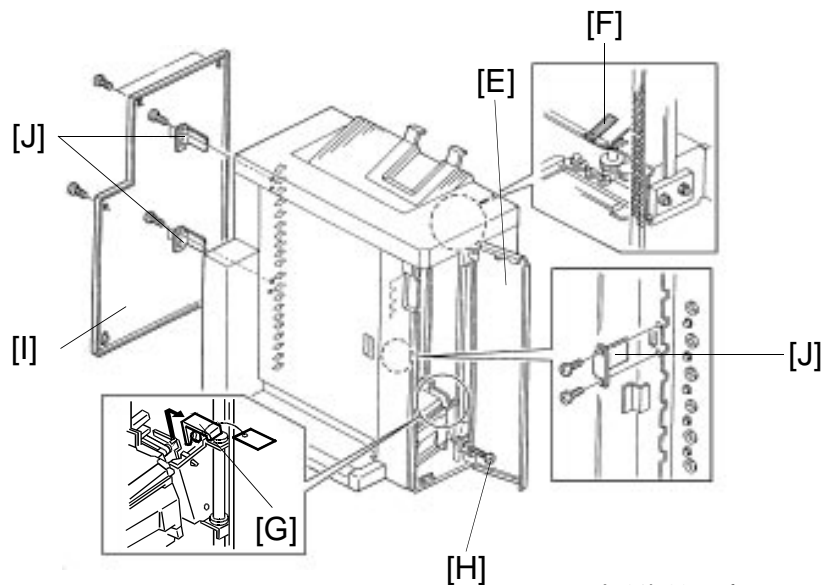

A5911502.wmf

CAUTION:

Unplug the copier power cord before starting the following procedure.

1. Remove the strip of filament tape [A] fixing the relay unit cover [B].
2. Remove the strips of filament tape [C] and remove the cushions [D] protecting the bins.
3. Open the front door [E], remove the strips of filament tape [F] fixing the jogger unit.
4. Remove the shipping retainer [G] fixing the grip unit.
5. Remove the screw [H] fixing the staple unit.
6. Remove the rear cover [I] (6 screws).
7. Remove the three brackets [J] supporting the vertical transport cover (2 screws each).

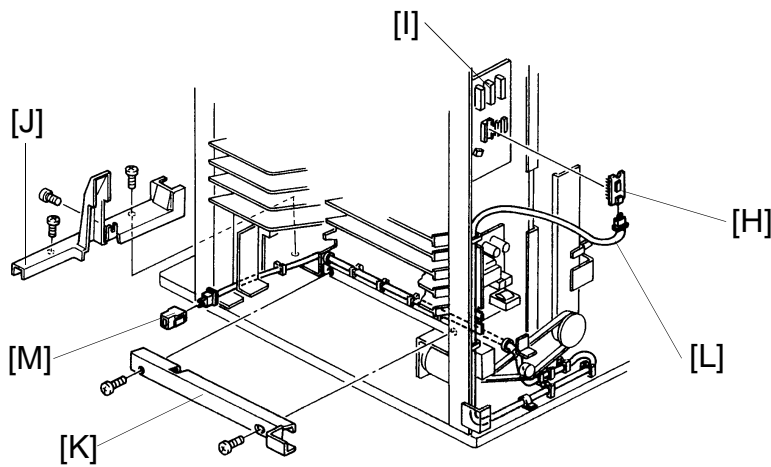
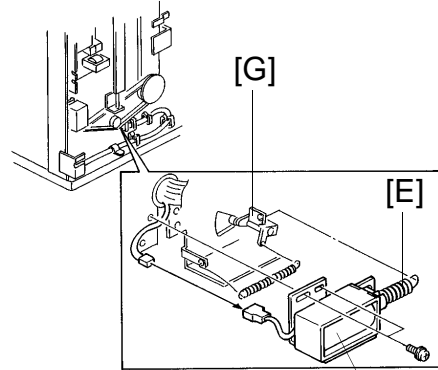
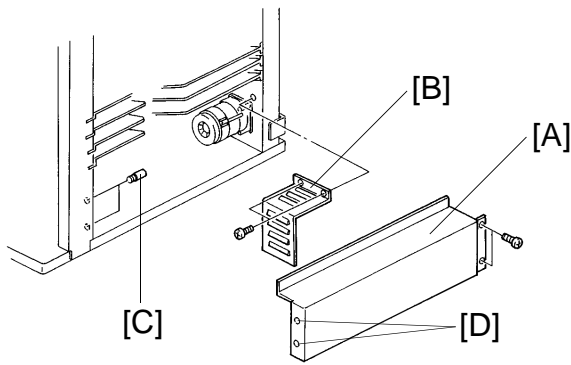

8. Remove the rear cover of the 1st sorter (6 screws).
9. Remove the lower right cover [A] (2 screws), motor cover [B] (2 screws), and 2 studs [C] from the 1st sorter. Install them on the 2nd sorter. (Set the studs into the holes [D] of the lower right cover.)
10. Hook the spring [E] of the relay gate solenoid [F] packed with the 2nd sorter to the relay gate lever [G] of the 1st sorter and fix the relay gate solenoid (2 screws with washer and 1 connector).
11. Set the interface board [H] packed with the 2nd sorter on the CN200 of the 1st sorter main board [I] so that the notch of the interface board is up.
12. Remove the front harness cover [J] (3 screws) and inner harness cover [K] (2 screws). Connect the optical fiber cable [L] packed with the 2nd sorter to the interface board and run the cable as shown in the illustration.
13. Install the relay connector [M] packed with the 2nd sorter to the end of the optical fiber cable [L].
14. Reinstall the inner harness cover [K].

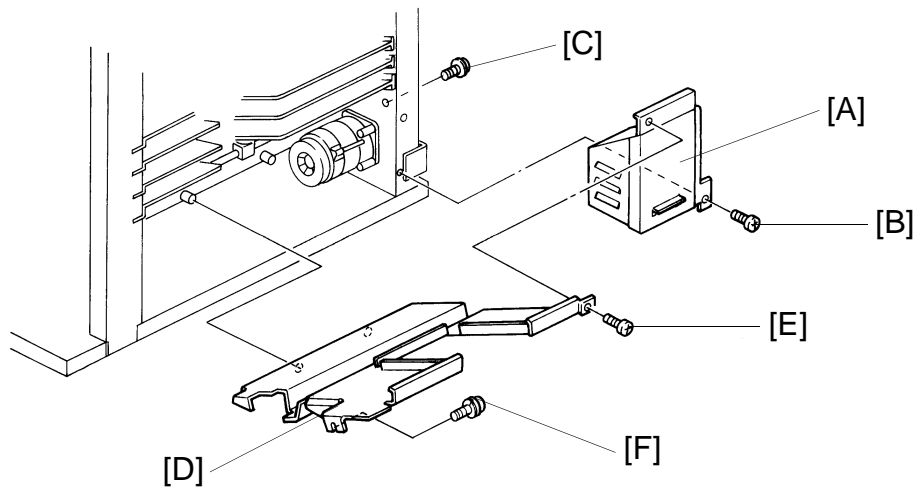

A591I513.img

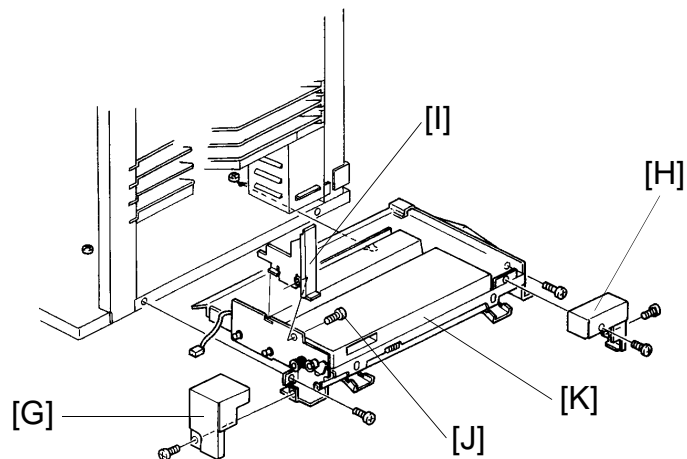

A591I514.img

15. Install the motor cover [A] (M4 x 6 pan head screw [B] and M4 x 6 screw with spring washer [C]) and the bin bottom bracket [D] (truss head screw [E] and double washer screw [F]) both packed with the 2nd sorter to the 1st sorter.
16. Remove the front cover [G] (1 screw) and the rear cover [H] (2 screw) of the relay unit.
17. Install the joint bracket [I] packed with the 2nd sorter (flat head screw [J]) on the relay unit [K].
18. Install the relay unit to the 1st sorter (2 M4 x 6 screws with spring washer).
19. Reinstall the rear cover [H] of the relay unit and the rear cover of the 1st sorter.

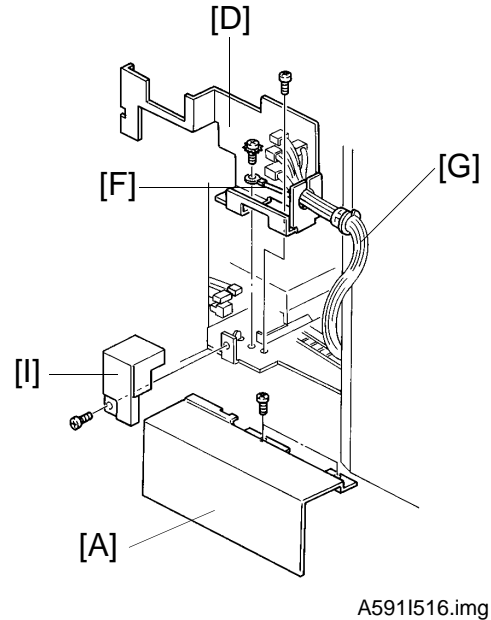
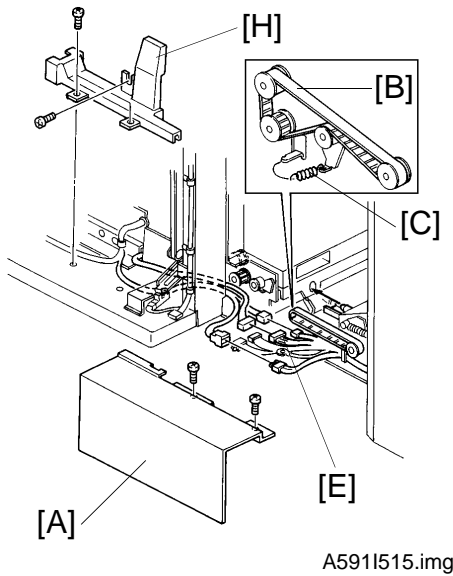

20. Remove the front cover [A] of the horizontal transport unit (2 screws).
21. Join the 2nd sorter to the relay unit and set the timing belt [B]. Then hook the spring [C] of the tension pulley bracket.
22. Install the harness cover bracket [D] (1 screw, M4 x 6) packed with the 2nd sorter to the relay unit.
23. Connect the three of the five connectors [E] from the 2nd sorter.
24. Fix the ground line [F] from the 2nd sorter to the relay unit (M4 x 8 with a star washer).
25. Pass the harness through the cutout of the bracket [D] and install the bushing [G] packed with the 2nd sorter.
26. Install the front cover [A] of the horizontal transport unit (1 screw).

N CAUTION

If the 1st sorter height adjustment is required again (this adjustment was done during the 1st sorter installation), do it before step 27. Otherwise, the harness may be caught in the threads of leveling adjuster.

27. Install the front harness cover [H] and the front cover [I] of the horizontal transport unit.

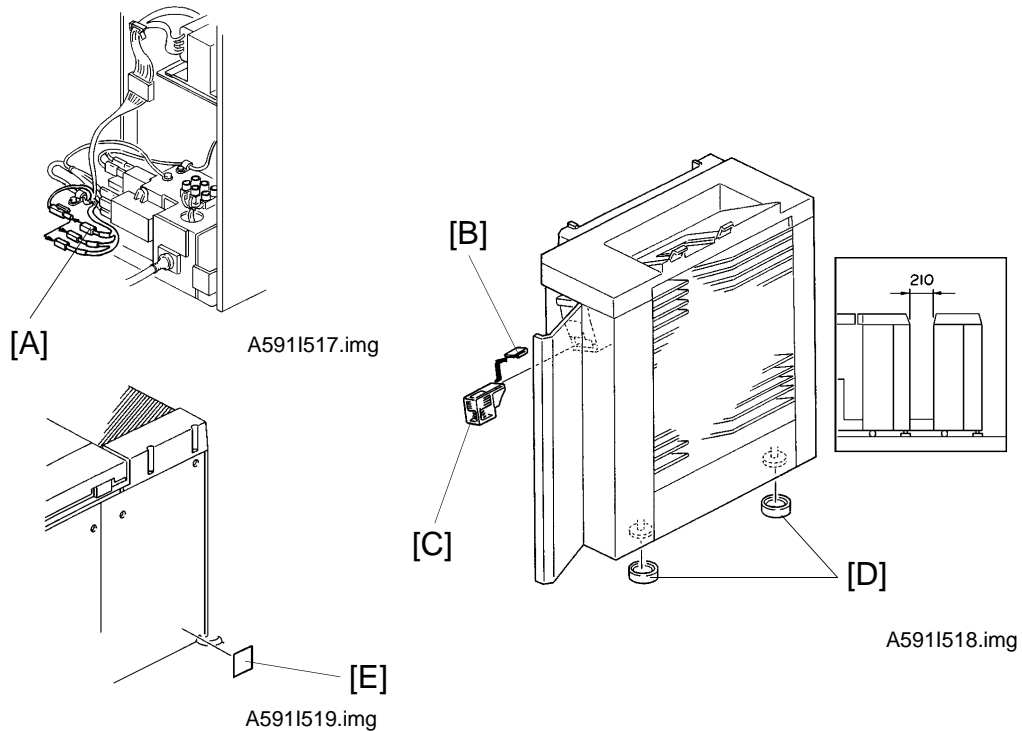

28. European version machines only

If the voltage of electrical power supply from wall outlets is 220 V or 240 V, change the voltage as follows:

- a) Disconnect the input line [A] from the 230 V connector.
- b) Connect the input line to the appropriate voltage (220 V or 240 V).

29. Reinstall the rear cover.

30. Open the front door of the sorter, remove the staple cover [B], and set the staple cartridge [C].

31. Put the two leveling shoes [D] under the feet. Adjust the sorter height by securing down feet so that the sorter is parallel to the copier.

N CAUTION

If the 1st sorter height adjustment is required again (this adjustment was done during the 1st sorter installation), do it before step 27. Otherwise, the harness may be caught in the threads of leveling adjuster.

32. Stick the decal [E] on the left rear cover of the copier beside the power cord.

33. Turn on the main switch of the copier and test the operation of the sorter stapler.

NOTE: The stapler will not be stapling for the first 10 or so copies until the first staple comes to the proper position from the cartridge.

4. SERVICE TABLES

4.1 TEST POINT TABLE (Main Board)

Number	Function
TP100	GND
TP101	5 V
TP102	24 V
TP103	Lower Staple Unit Trigger (SP Mode)

4.2 LED AND VARIABLE RESISTOR TABLE (Main Board)

LED No.	VR No.	Function
100	100	Adjusts jam sensor sensitivity
101	101	Adjusts bin sensor sensitivity

4.3 FUSE TABLE

Number	Specification	Location
Fuse 100	125 V 5 A	Main Board
Fuse 1	125 V 5 A	PSU

4.4 DIP SW TABLE

DIP SW100 (MODE) SP mode

1	2	3	4	Function
0	0	0	0	Initial Normal Setting
1	0	0	0	Sorter Free Run
0	1	0	0	Staple Unit Free Run
1	1	0	0	Sorter & Staple Unit Free Run
0	0	1	0	Lower Staple Unit
0	0	0	1	Bin/Jam Sensor Adjustment

0: OFF 1: ON

1. "Sorter Free Run", "Staple Unit Free Run" or "Sorter & Staple Unit Free Run" starts operation when the DIP switches are set as shown in the table.
2. "Lower Staple Unit" starts operation when TP103 is short-circuited to TP100 (GND), after setting DIP SW100-3 to 1.
3. Bin/Jam sensor can be adjusted by VR100 and VR 101 after setting DIP SW100-4 to 1.

Operation

1. Sorter Free Run
 - 1) Main motor turns on.
 - 2) Side bar moves to the A4 position.
 - 3) By-pass tray gate moves to the upper position.
 - 4) Pressure release solenoid is energized for 2.4 seconds.
 - 5) Bin solenoids turn on at the 1st bin continuing in order down to the 20th bin.
 - 6) Jogger moves at each bin.
 - 7) Machine stops operation for one second and then repeats the above operation from 1).
2. Staple Unit Free Run

The sorter stapler repeats the staple operation in order from the 1st bin to the 20th bin.
3. Sorter and Staple Unit Free Run

The sorter stapler works as if 20 sets of 2 A4 papers are present and sorted in auto staple mode.
4. Lower Staple Unit

Staple unit lowers until it reaches to the 20th bin and stops.

DIP SW101 (STAPLE) Staple position adjustment

1	2	3	4	Staple Position
0	0	0	–	Standard Value
1	0	0	0/1	0.5 mm shifted
0	1	0	0/1	1.0 mm shifted
1	1	0	0/1	1.5 mm shifted
0	0	1	0/1	2.0 mm shifted
1	0	1	0/1	2.5 mm shifted
0	1	1	0/1	3.0 mm shifted
1	1	1	0/1	3.5 mm shifted
–	–	–	0	(+) Direction (farther from the edge)
–	–	–	1	(–) Direction (closer to the edge)

0: OFF 1: ON –: Not concerned

DIP SW101-1, 101-2, and 101-3 determines the length the staple position is shifted.

DIP SW101-4 determines the shift direction up or down.

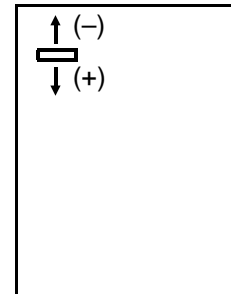

4.5 MAINTENANCE TABLE

Items	Standard Procedure	Tools
Rollers	Clean the rollers if they are soiled.	A cloth dampened with alcohol
Bins	Clean the rollers if they are soiled.	A cloth dampened with alcohol
Sensors	Clean the rollers if they are soiled.	A cloth dampened with alcohol
Bushings	Lubricate the bushings if they make noise.	Launa-40 oil or equivalent
Gears	Lubricate the gears if they make noise.	Grease G-501
Worm Gear	Lubricate the worm gear if it makes noise.	Mobil temp 78

5. REPLACEMENT AND ADJUSTMENT

5.1 BIN/JAM SENSOR ADJUSTMENT

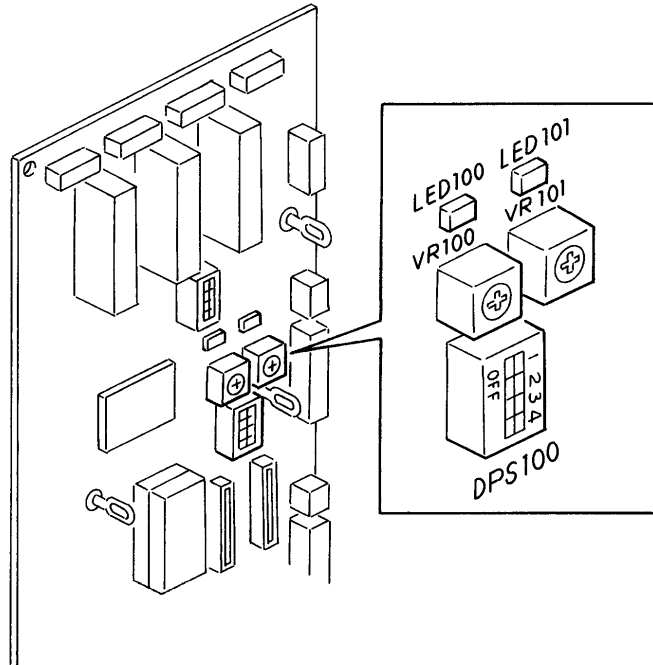

A591R500.img

NOTE: This adjustment should be performed when the main board or the bin/jam sensor is replaced.

1. Remove the rear cover.
2. Confirm that there is no paper on the bins.
3. Turn on the DIP SW100-4 on the main board.
4. Turn the VR100 and VR101 so that the LED100 and LED101 are at the ON/OFF threshold (just turns off).
5. Turn off the DIP SW100-4.

5.2 STAPLE POSITION ADJUSTMENT

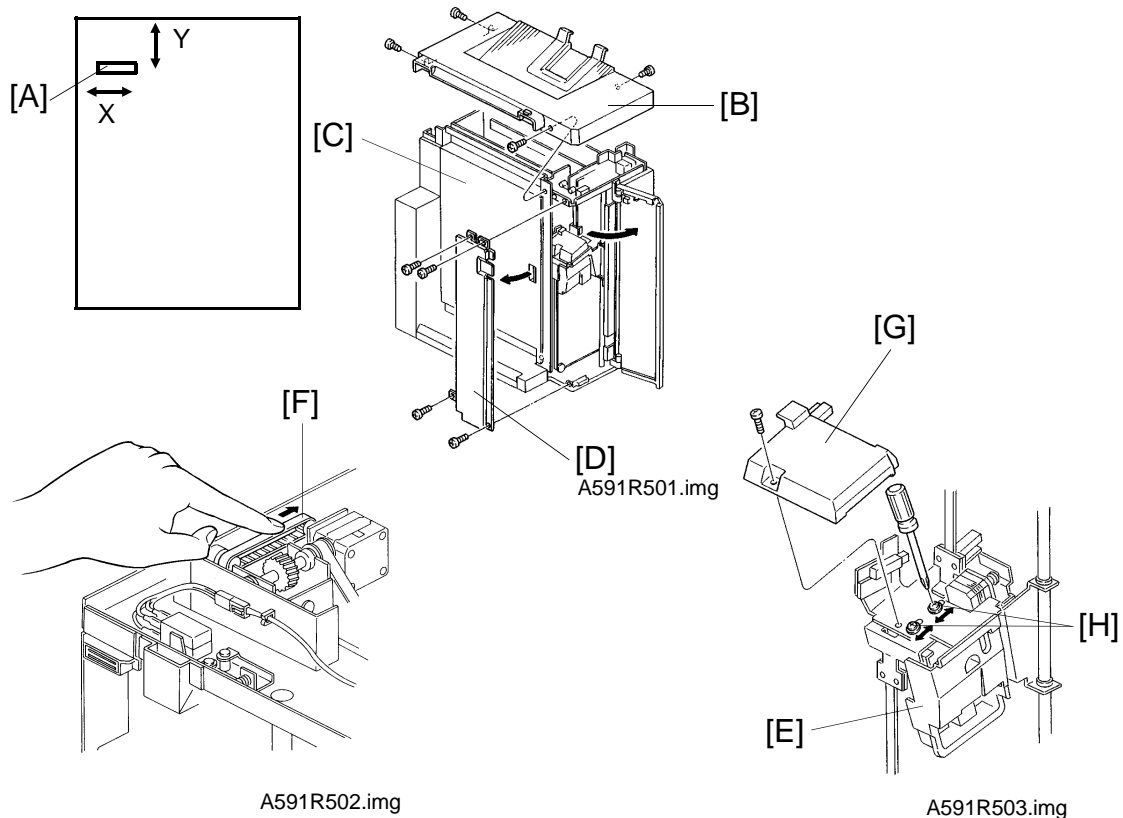

NOTE: This adjustment should be performed when the main board or staple unit is replaced.

X Direction

1. Check the position of the staple [A] on the copy paper.
2. Remove the upper cover [B] (4 screws), open the vertical transport door [C] and remove the left front cover [D] (4 screws).
3. Lower the staple unit [E] by manually turning the timing belt [F] of the staple unit positioning motor in the direction of the arrow.
4. Remove the staple unit upper cover [G] (1 screw).
5. Loosen the two screws [H] and adjust the staple unit position.
6. Retighten the screws [H].

Y Direction

1. Check the position of the staple [A] on the copy paper.
2. Remove the rear cover.
3. Adjust the staple position by setting the DIP SW101.

5.3 SIDE BAR ADJUSTMENT

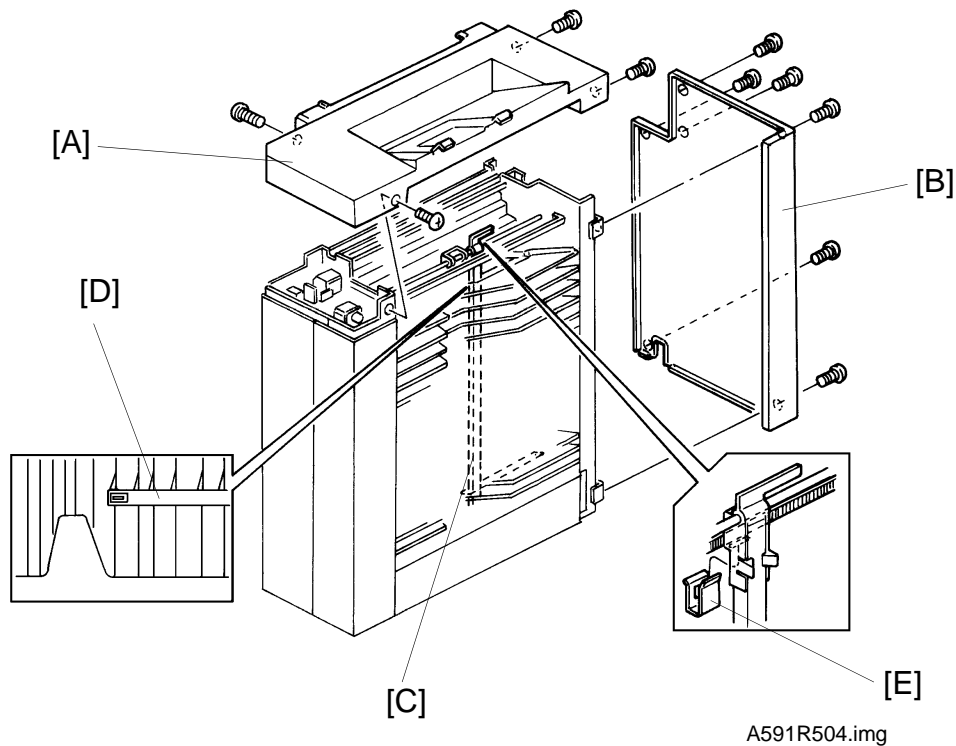

1. Remove the upper cover [A] and the rear cover [B].
2. Manually move the side bar [C] towards the front side bar slot [D], by turning the side bar motor manually.
3. Confirm that the side bar is parallel and contacts both the 1st and 20th bin side bar slots front side.
4. If improper contact is observed between the 1st and 20th bin, remove the timing belt clamp [E] and reposition the side bar position.

5.4 BELT TENSION ADJUSTMENT

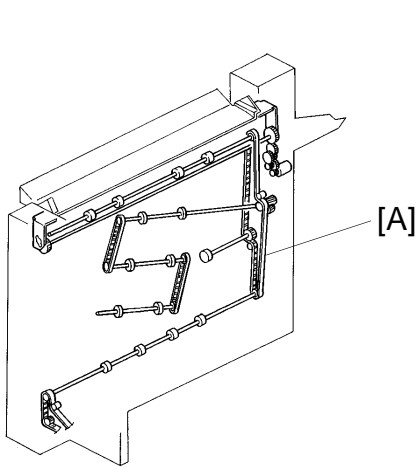

A591R505.img

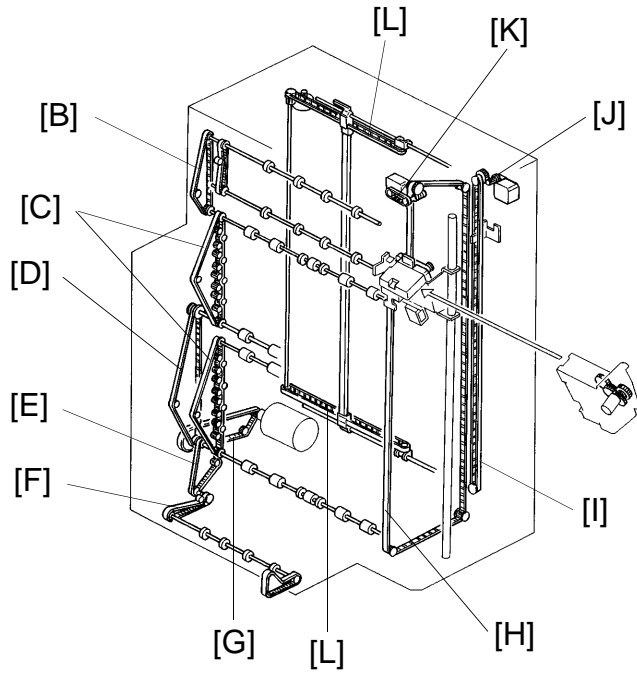

A591R508.img

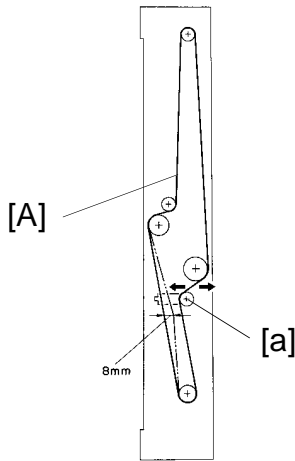

A591R506.img

1. Detach the diagonal transport unit from the copier, remove the rear cover of the diagonal transport unit, and adjust the belt [A] tension with tightener [a].

Standard [A]: 8 mm deflection at 100 ± 30 g pressure

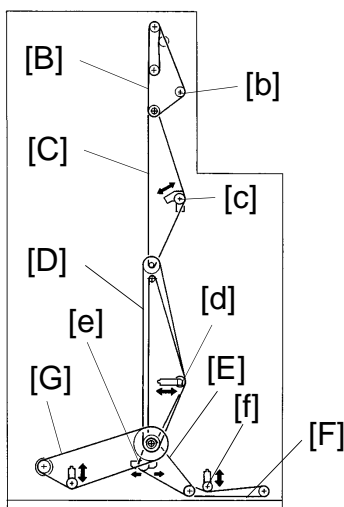

A591R507.img

2. Remove the rear cover of the distribution unit and adjust the belt [B], [C], [D], [E], [F], [G] tension with tightener [b], [c], [d], [e], [f], [g].

<Standard>

- [B]: 5 mm deflection at 80 ± 30 g pressure
- [C]: 5 mm deflection at 140 ± 40 g pressure
- [D]: 5 mm deflection at 100 ± 50 g pressure
- [E]: 5 mm deflection at 100 ± 50 g pressure
- [F]: The distance between the belt and the bottom plate is 0.7 to 2.0 mm
- [G]: 5 mm deflection at 100 ± 50 g pressure

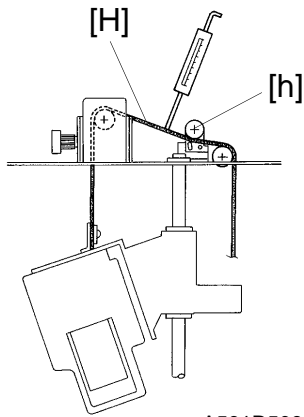

A591R509.img

3. Remove the upper cover of the distribution unit and adjust the belt [H] tension with the tightener [L].
Standard [H]: 5 mm deflection at 170 ± 30 g pressure

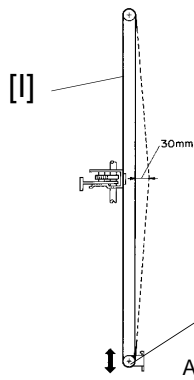

A591R510.img

4. Remove the upper cover and right cover then adjust the belt [I] tension with the tightener [i].
Standard [I]: 30 mm deflection at 200 ± 30 g pressure

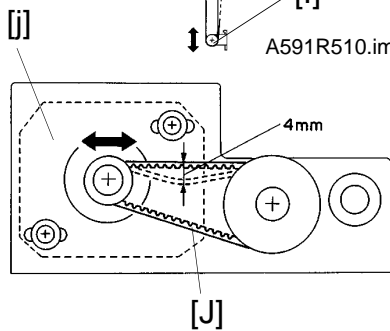

A591R511.img

5. Remove the upper cover and adjust the belt [J] tension with the motor position bracket [j].
Standard [J]: 5 mm deflection at 200 ± 30 g pressure

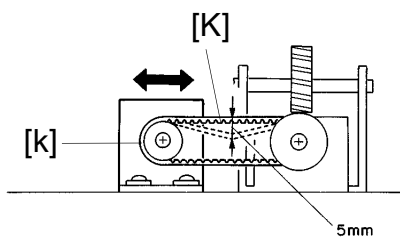

A591R512.img

6. Remove the upper cover and adjust the belt [K] tension with the motor position bracket [k].
Standard [K]: 5 mm deflection at 150 ± 50 g pressure

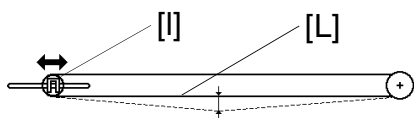

A591R513.img

7. Remove the upper cover and adjust the belt [L] tension with the tightener [I].
Standard [L]: 10 mm deflection at 200 ± 30 g pressure

5.5 STAPLE ELEVATOR UNIT REMOVAL

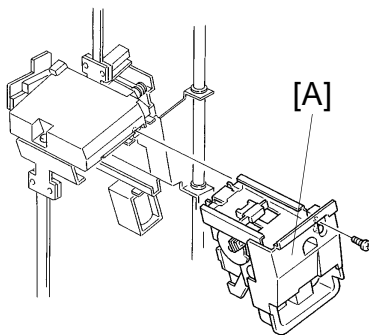

A591R514.img

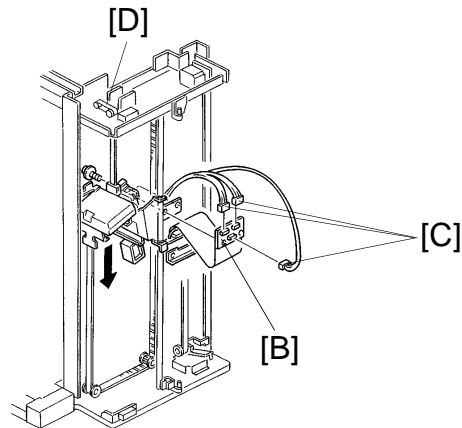

A591R515.img

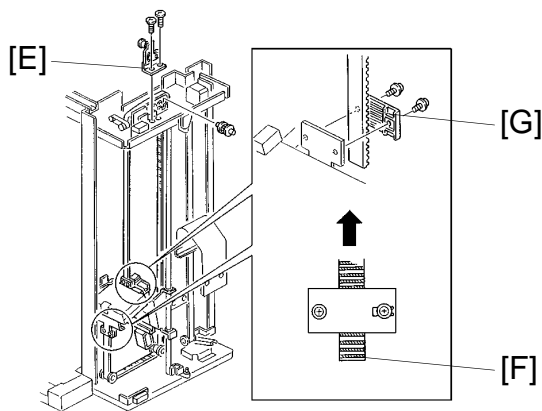

A591R516.img

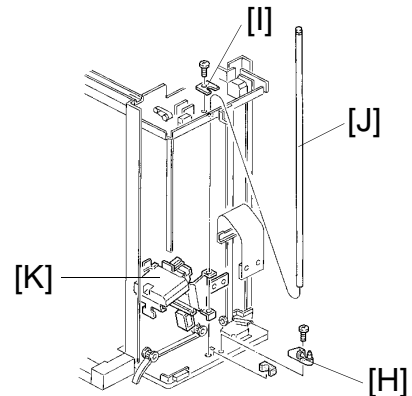

A591R517.img

1. Remove the upper cover, the front door, the right front cover.
2. Remove the staple unit [A] (1 screw).
3. Remove the two screws fixing the flat cable [B] and disconnect the three connectors [C].
4. Lower the staple elevator unit by turning the timing belt [D] of the staple unit positioning motor manually until it reaches to the lower limit.
5. Remove the idle pulley [E] (2 screws).
6. Count the number of the timing belt [F] pitches that stickout of the fixing plates [G]. Then remove the two fixing plates (2 screws each).
7. Remove the front door hinge [H] (1 screw) and the elevator guide bar fixing bracket [I] (1 screw).
8. Slide out the elevator guide bar [J] and remove the elevator unit [K].

NOTE: When reassembling the machine, fix the belt with the fixing plate as it was confirmed in step 6.

5.6 BIN REMOVAL

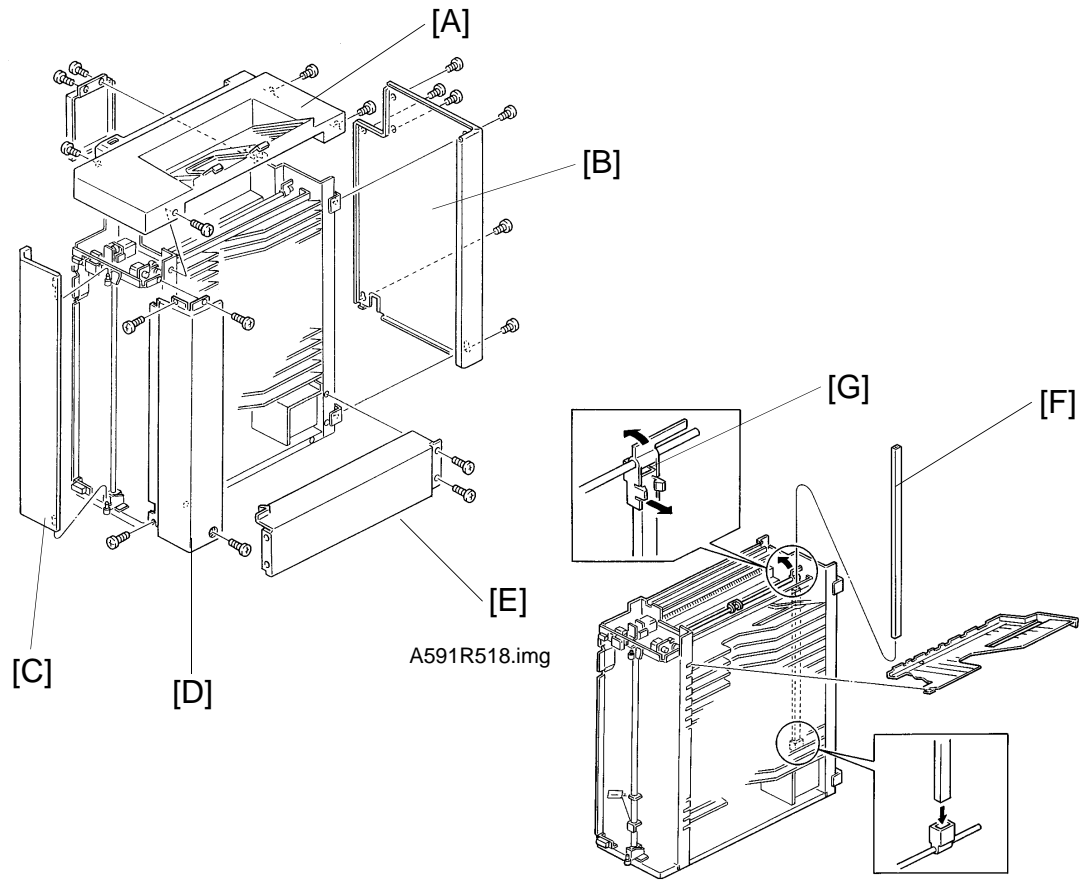

1. Remove the upper cover [A], the rear cover [B], the front door [C] the right front cover [D], and the lower right cover [E].
2. Remove off the side bar [F] from the side bar holder [G] and remove it.
3. Remove the appropriate bin.

5.7 BIN/JAM SENSOR REMOVAL

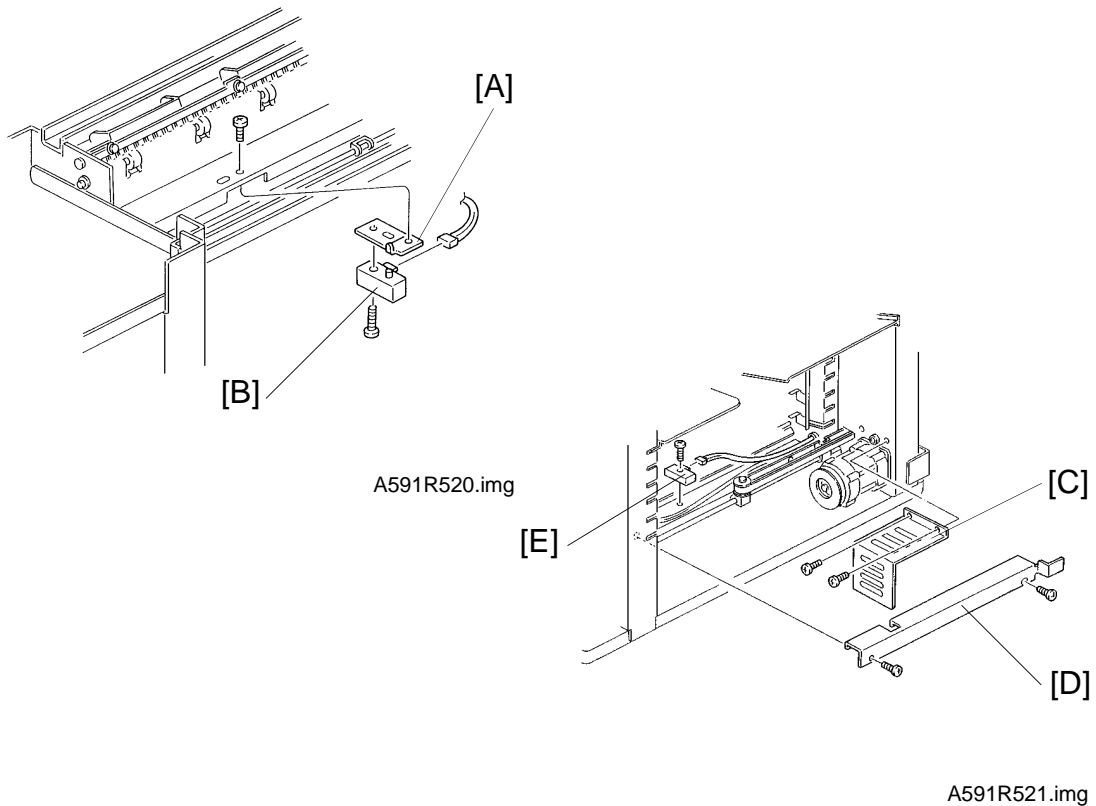

Upper Bin/Jam Sensor

1. Remove the upper cover (4 screws).
2. Remove the bin/jam sensor bracket [A] (1 screw).
3. Replace the upper bin/jam sensor [B] (1 screw).
4. Adjust the sensor sensitivity by turning VR100 and 101 on the main board.

Lower Bin/Jam Sensor

1. Remove the motor cover [C] (2 screws) and the harness cover [D] (2 screws).
2. Remove the bottom 5 bins.
3. Replace the lower bin/jam sensor [E] (1 screw).
4. Adjust the sensor sensitivity by turning VR100 and 101 on the main board.

5.8 SORTER DETACHMENT

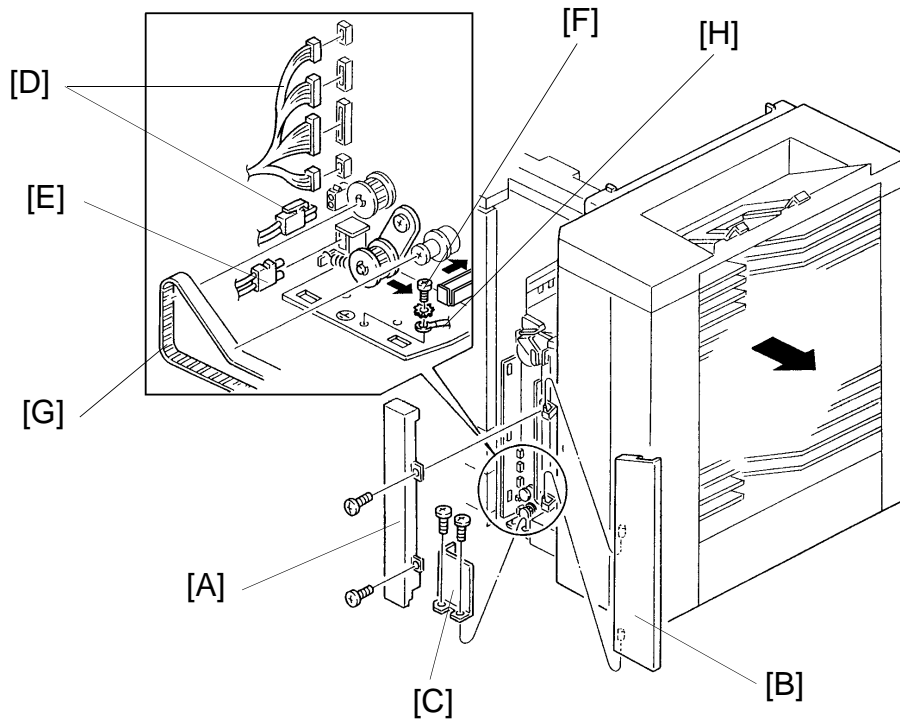

A591R522.img

1. Remove the front cover [A] of the diagonal transport unit (2 screws) and remove the front door [B].
2. Remove the harness cover [C] (2 screws).
3. Disconnect the 5 connectors [D], the fiber optic cable [E] and remove the screw [F] fixing the ground line.
4. Take the timing belt [G] off the pulleys.
5. Press the lock lever [H] to the allow direction and detach the sorter from the copier.